

*Featherlite*<sup>®</sup>



TURNING THE  
**TABLES**  
IN YOUR FAVOUR

[www.featherlitefurniture.com](http://www.featherlitefurniture.com)

# Enrich

Enrich has a sleek under structure and deeply integrates art & practicability. The side cabinets deftly includes opening door cabinets, which can satisfy varied private storage demands. It's just a turn-back to switch between private space and an office space.



A  
Vertical split storage



B  
2 Door storage



C  
Horizontal split storage



Enrich Discussion Table



Enrich Conference Table

Note: Extension has to be pre determined and order for RHS / LHS

## Technical Specifications

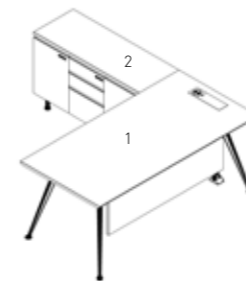

1. Main Table: W 1800 x D 900 x H 750mm  
W 2100 x D 900 x H 750mm  
2. Extension: W 1200 x D 450 x H 750mm

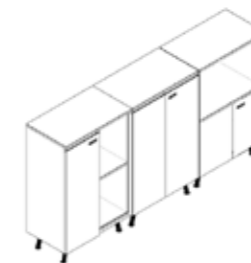

Storage A/B/C  
W 750 x D 450 x H 1500mm



W 1800 x D 900 x H 750mm  
W 2400 x D 1200 x H 750mm



Ø 900 x H 750mm  
Ø 1050 x H 750mm  
Ø 1200 x H 750mm

# Signature

Reimagining the simple office desk as an object of refined sophistication, Signature is an executive design at the top of its game. The desk pairs a smooth glass surface with angular, cubic cabinets in a display of contrasts that makes Signature the deserved centre piece of the office environment.

It has a floating look & gives a streamlined user experience that focuses on practicality and space. A desk to make an impression and make life easy.



Note: Extension has to be pre determined and order for RHS / LHS

## Technical Specifications

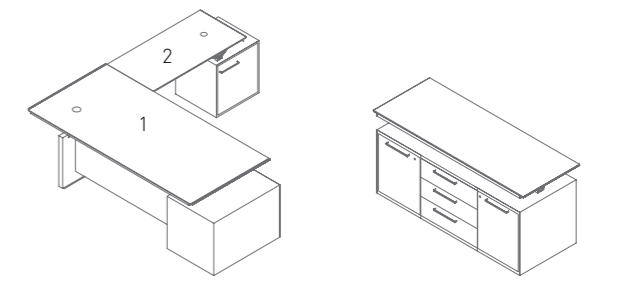

1. Main Table: W 2100 x D 1000 x H 750mm  
W 2300 x D 1000 x H 750mm  
2. Extension: W 1400 x D 550 x H 750mm

W 1500 x D 600 x H 750mm

# Zen Executive Series

## The Less The Better

Introducing Zen series, the new executive designs that harmonize space, form and function. Thoughtful, compact, yet sophisticated designs which offer an organised workspace. The relaxed colours combined with natural wood patterns deliver a pleasing experience at work



Executive Table



Zen Conference Table



Storage 1 - 2nos.  
Screen 1 - 1no.

Storage 2 - 1no.  
Storage 1 - 1no.  
Screen 1 - 1no.

Note: Extension has to be pre determined and order for RHS / LHS

## Technical Specifications

Executive Table(With Modesty)

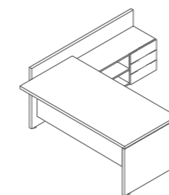

W 1500 x D 900 x H 750mm  
W 1800 x D 900 x H 750mm

Pedestal on Castors



W 450 x D 400 x H 450mm

Conference

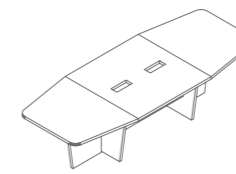

W 3000 x D 1200 x H 750mm

Standard Modules



STORAGE 1  
H700 x W750  
x D400mm

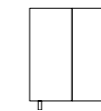

STORAGE 2  
H900 x W750  
x D400mm



STORAGE 3  
H1200 x W750  
x D400mm



SCREEN 1  
H900 x W1800  
x D25mm



SCREEN 2  
H900 x W900  
x D25mm  
(Used with a single storage)

# Elite

A classic L shape office table finished in rich walnut veneer integrates elements of uprightness and roundness, turning hard edges into modesty and humbleness. Smooth touch supports & roundness making it more appealing & beautiful.



# Urbane

Beautifully crafted Desk with an executive return, with wooden finish understructure making it a reflection of elegance and beauty. Executive desk supporting the wire management comprehensively, making the work, more humanized.



## Technical Specifications

Note: Extension has to be pre determined and order for RHS / LHS

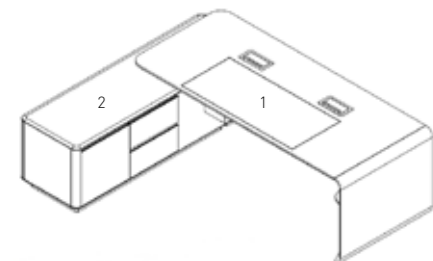

1. Main Table: W 2200 x D 950 x H 760mm  
2. Extension: W 1900 x D 600 x H 620mm



## Technical Specifications

Note: Extension can be assembled same on either the RHS / LHS

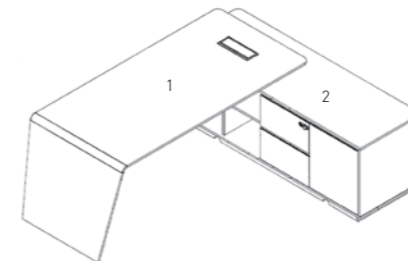

1. Main Table: W 2400 x D 900 x H 760mm  
2. Extension: W 1800 x D 600 x H 660  
W 2000 x D 800 x H 760mm  
W 1600 x D 550 x H 660



# Senate

(HT-501/ 501A)

Senate is a desk inspired by the philosophies of minimalism and usability. Optimised to fit into and subtly enhance its environment, Senate is a desk for the design focused consumer. It has elegant & beautiful dark wood cabinets. This desk emerges as an object of sleek, uninterrupted lines that speaks of power in the workplace.



# Senate

(HT-528)



# Senate

(HT-531)



## Technical Specifications

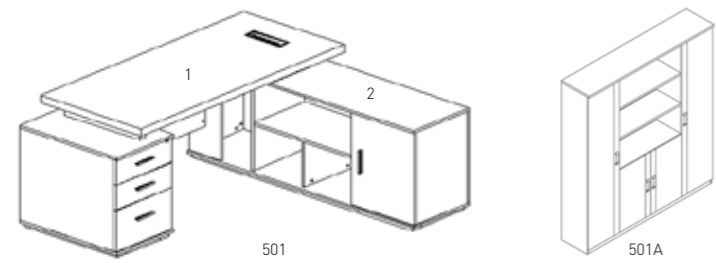

1. Main Table: W 2000 x D 800 x H 780mm  
W 2200 x D 800 x H 780mm  
2. Extension: W 1010 x D 500 x H 650mm

W 1800 x D 400 x H 2000

Note: Extension can be assembled same on either the RHS / LHS

## Technical Specifications

Note: Extension can be assembled same on either the RHS / LHS

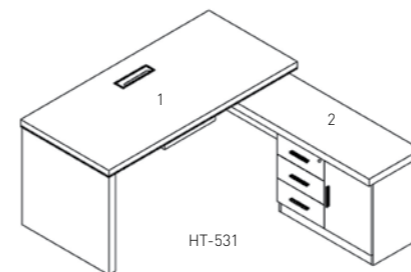

1. Main Table: W 1600 x D 750 x H 780mm  
2. Extension: W 905 x D 440 x H 650

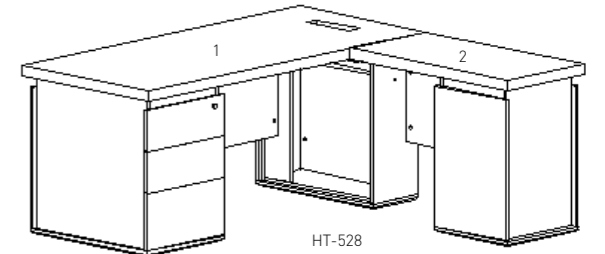

1. Main Table: W 1800 x D 750 x H 780mm  
2. Extension: W 905 x D 440 x H 750mm

# Edge

Edge- designed to suit all your office needs. It is made to last, comes with a two year warranty, and is light on your budget. The very design of this product is such that it is extremely portable and easy to install. It is also possible to relocate, rearrange, and reassemble with great ease.



Edge Conference Table

## Technical Specifications

### Configurations

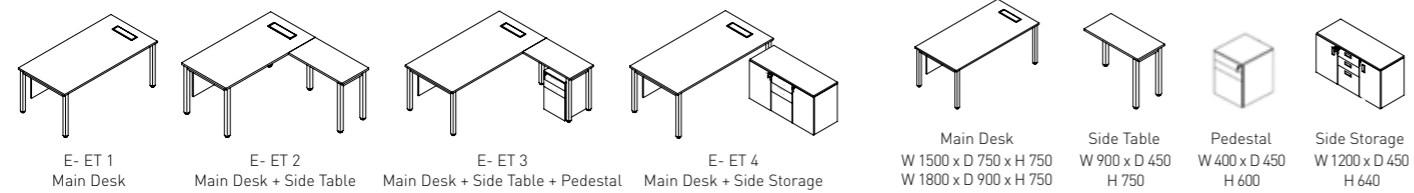

Note: Extension can be assembled same on either the RHS / LHS

### Discussion and Conference

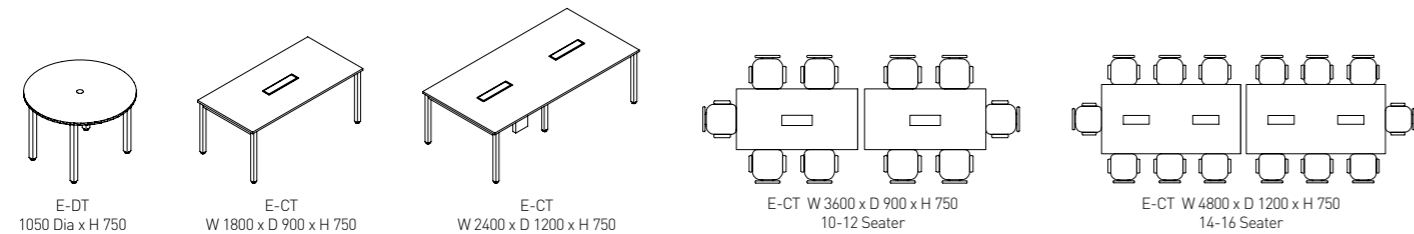

# Integrate

Unfussy and approachable, Integrate pairs down the classic office desk to its essentials. Providing everything the modern worker needs but with none of the complications. Integrate boasts a classic aesthetic with a modern twist. Angular legs and fixtures meet with beautiful pine surfaces in a piece of design that is attractive and beautiful.



Integrate Conference Table

## Technical Specifications

Note: Extension has to be pre determined and order for RHS / LHS

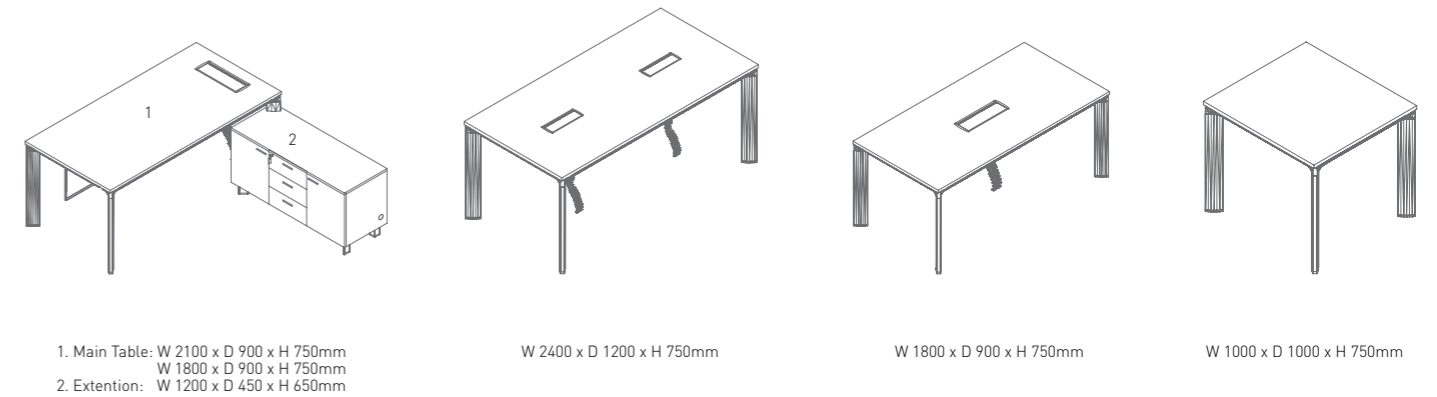

# Versaline

Featherlite brings Versaline to your workspace. A complete collection of durable, economical, flexible and stylish office desks along with storage units to make the work environment stylish, efficient and spacious.



V-MS 1

V-MS 2



V-ML 1



V-ML 2



Versaline Conference Table



Versaline Discussion Table

## Technical Specifications

Note: Extension can be assembled same on either the RHS / LHS

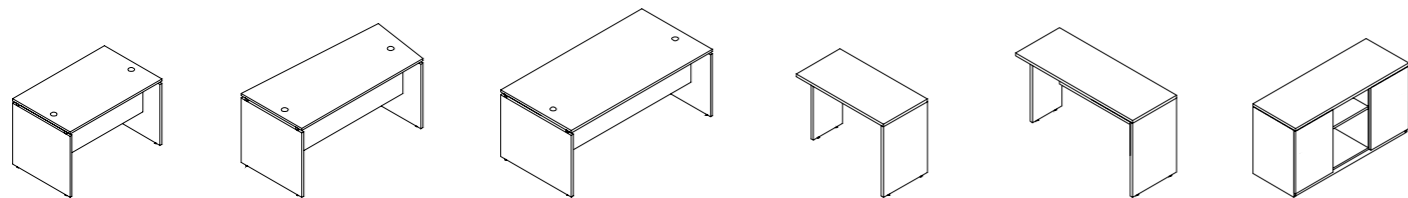

V-MT 1275  
W 1200 x D 750 x H 750

V-MT 1575  
W 1500 x D 750 x H 750

V-MT 1890  
W 1800 x D 900 x H 750

V-ST 9045 (LH & RH)  
W 900 x D 450 x H 750

V-ST 1245 (LH & RH)  
W 1200 x D 450 x H 750

V-CZ  
W 1200 x D 450 x H 750

## Technical Specifications

### Discussion and Conference

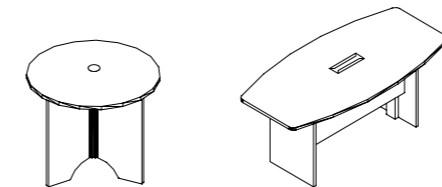

V-DT 1050  
1050 DIA

1. V-CT 1890: W 1800 x D 900 x H 750  
2. V-CT 2412: W 2400 x D 1200 x H 750

### Storage

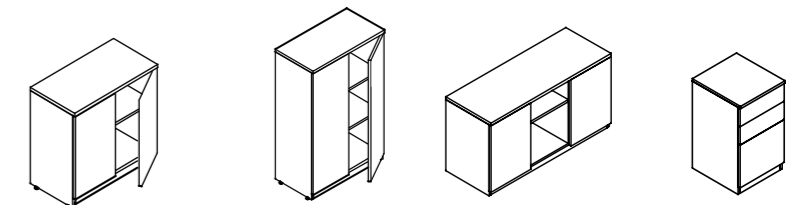

1. V-S 7575: W 750 x D 400 x H 750  
2. V-S 9075: W 900 x D 400 x H 750

V-S 90120  
W 900 x D 400 x H 1200

V-CZ  
W 1200 x D 450 x H 750

V-2D1F  
W 400 x D 435 x H 640



# Collaborate

User friendly is the basis of Collaborate design; every detail shows the infinite satisfaction of all different needs. The main desktop comes with a Height adjustable side storage & a credenza. Over all setting supports different ways of working giving a break to the sedentary workstyle. Side stage has a pneumatic lifting function, which meets the need of sitting and standing posture, as well as for open discussions.



# Height Adjustable Table

The Motorized Height Adjustable Table is the result of intricate study of ergonomics in office space management and the key to user satisfaction and increased productivity. By preventing a sedentary posture, they ensure reduced employee health risks. This high quality automated system coupled with its innovative and sleek design is another step towards better ergonomics.



Collaborate Conference Table



Collaborate Discussion Table

## Technical Specifications

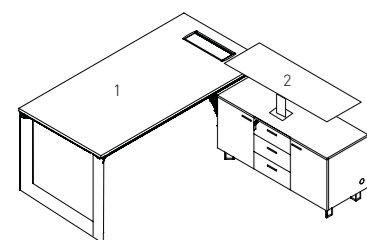

With Height Adjustable Extension

- 1. Main Table: W 1800 x D 900 x H 750mm  
W 2100 x D 900 x H 750mm
- 2. Extension: W 1050 x D 450 x H 750mm

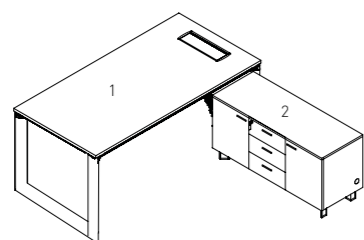

Without Height Adjustable Extension

- 1. Main Table: W 1800 x D 900 x H 750mm  
W 2100 x D 900 x H 750mm
- 2. Extension: W 1050 x D 450 x H 750mm



- W 1500 x D 900 x H 750mm
- W 1800 x D 900 x H 750mm



- Ø 900 x H 750mm
- Ø 1050 x H 750mm
- Ø 1200 x H 750mm

Note: Extension can be assembled same on either the RHS / LHS

## Technical Specifications



Thansau Maple

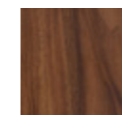

Walnut



Digital remote with 4 programmable presets

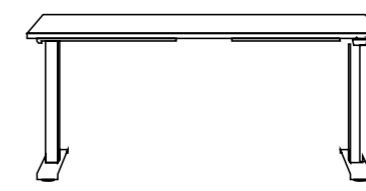

- Speed: 33mm/s
- Max. Load Capacity: 90kg

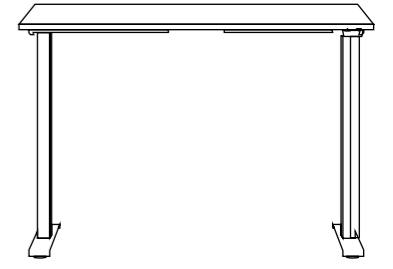

- Tables Dimensions: W 1500 x D 750mm
- Height Range: 680 - 11800mm

# Level-Up

Height Adjustable Tables



Level Up-I



Height Adjustment Controller  
2 USB Type-A Ports and 1 USB Type-C Port



Level Up-II



Height Adjustment Controller  
Four Memory Positions

# Motion Game

Gaming Height Adjustable Tables



Motion Game-I



Integrated Control Pad  
Carbon Fiber Texture Surface



Controller Rack  
RGB Lighting



Motion Game-II



Cup Holder  
Carbon Fiber Texture Surface  
RGB Lighting

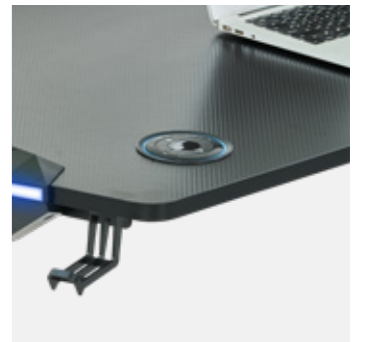

Headphone Hook  
Intuitive Up-Down Adjustment

## Technical Specifications

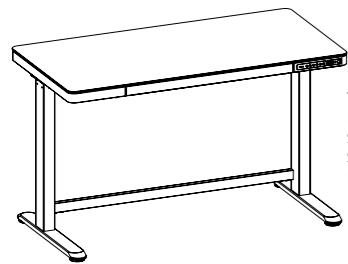

Level Up - I

Tables Dimensions: 1202mm x 602mm  
Height Range: 720 - 1210mm  
Speed: 25mm/s  
Stroke: 490mm  
Max. Load Capacity: 50kg

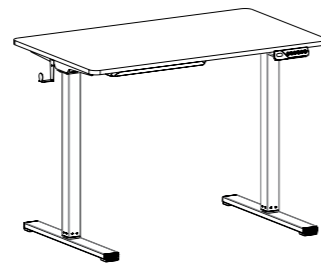

Level Up - II

Tables Dimensions: 1002mm x 602mm  
Height Range: 730 - 1210mm  
Speed: 25mm/s  
Stroke: 480mm  
Max. Load Capacity: 50kg

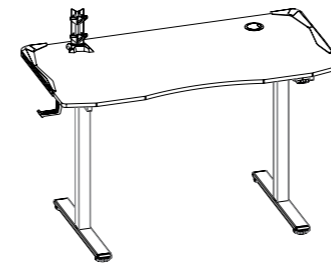

Motion Game - I

Tables Dimensions: 1200mm x 600mm  
Height Range: 730 - 1210mm  
Speed: 25mm/s  
Stroke: 480mm  
Max. Load Capacity: 50kg

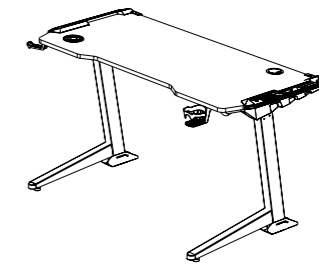

Motion Game - II

Tables Dimensions: 1250mm x 602mm  
Height Range: 720 - 1210mm  
Speed: 25mm/s  
Stroke: 490mm  
Max. Load Capacity: 40kg

## Technical Specifications

# NOMAD

Nomad mobile white board and monitor stand simplifies the meetings & collaboration among the team members to generate innovative ideas. Designed with all technological capabilities and portability to support & enhance meetings, brain storming sessions & making it so flexible & agile in engaging the colleagues, in any part of the Office.



TV + Marker Board + Storage



TV + Marker Board + Soft Board

TV + Marker Board

2 Sided Marker Board

## Specifications

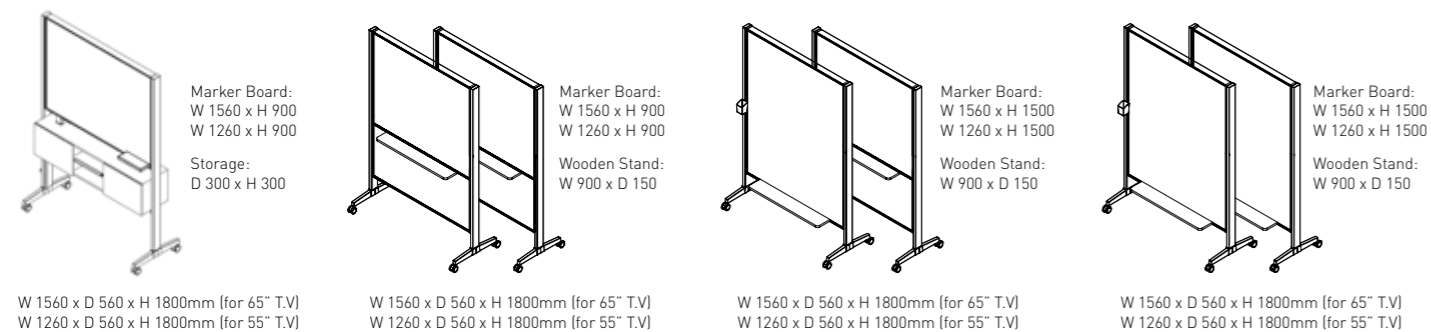

# Folding Tables

Sleek and stylishly designed multi-purpose training tables, with lockable castors. Easy to assemble, fold, move and place into different configurations. This versatile table complements and enhances your corporate training area with its robust look and functionality.



Type A

Type B

Inter Locking System

Stackable

- |                          |                          |
|--------------------------|--------------------------|
| W 900 x D 600 x H 750mm  | W 900 x D 750 x H 750mm  |
| W 1050 x D 600 x H 750mm | W 1050 x D 750 x H 750mm |
| W 1200 x D 600 x H 750mm | W 1200 x D 750 x H 750mm |
| W 1350 x D 600 x H 750mm | W 1350 x D 750 x H 750mm |
| W 1500 x D 600 x H 750mm | W 1500 x D 750 x H 750mm |

## Combinations

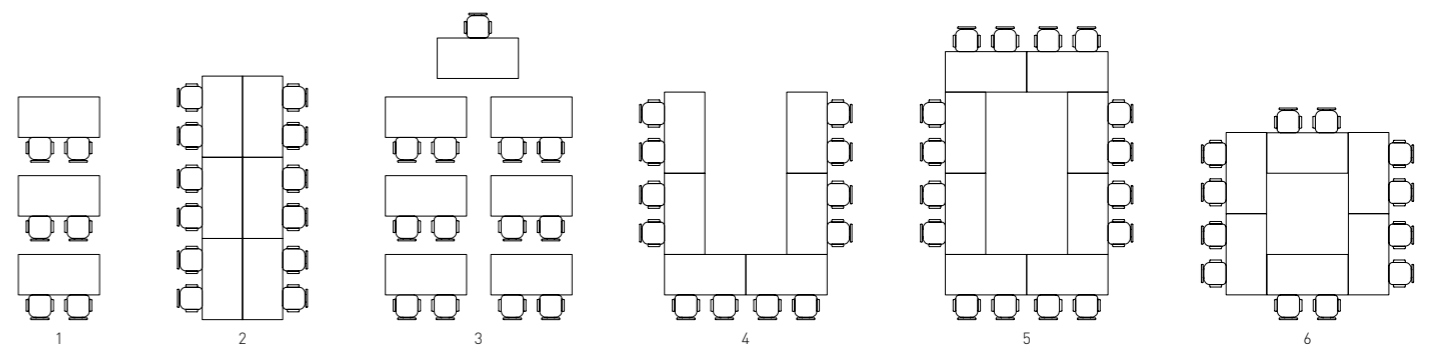

# Lockers

Wooden

Lockers offer you your own personal and private storage in a public space. These lockers defy convention in looks yet are robust and resilient making them ideal for industrial, leisure, public and commercial areas.



6 Drawers W 400 x D 450 x H 1830  
 4 Drawers W 400 x D 450 x H 1830  
 2 Drawers W 400 x D 450 x H 1830  
 2 Drawers W 400 x D 450 x H 1830 (Coat Storage)

### Features

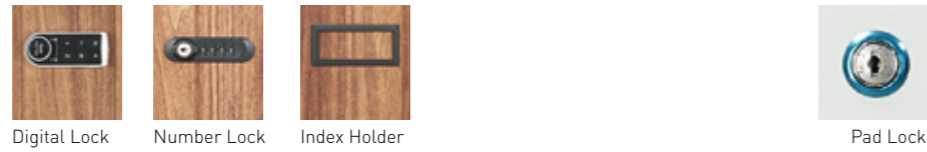

Digital Lock Number Lock Index Holder Pad Lock

# Lockers

Metal



6 Drawers W 900 x D 4505 x H 1830  
 KD-042-4 W 380 x D 450 x H 1850  
 KD-042-6 W 760 x D 450 x H 1850

### Features

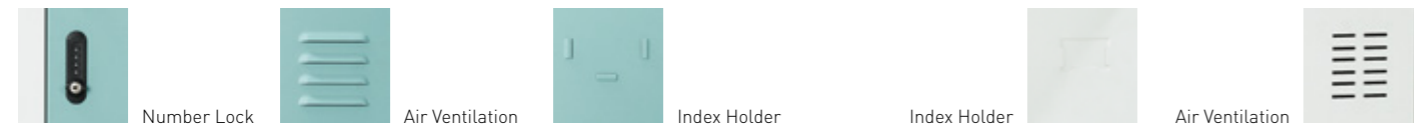

Number Lock Air Ventilation Index Holder Index Holder

### Features



Air Ventilation

# Executive Filing Cabinets

The executive range offers a filing capacity of 2.1 metres of linear storage. It has larger internal drawer dimensions, cleaner aesthetics and styled looks with a swan neck handle design.



KD-009  
 Filing Cabinet 4 Drawers  
 W 460 x D 620 x H 1331

### Features

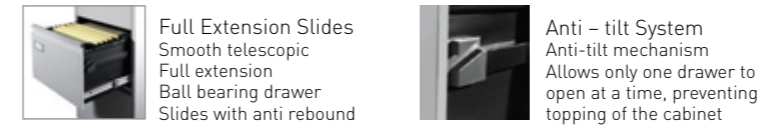

Full Extension Slides Smooth telescopic Full extension Ball bearing drawer Slides with anti rebound  
 Anti-tilt System Anti-tilt mechanism Allows only one drawer to open at a time, preventing topping of the cabinet



# Cupboards



KD-099 Swing doors with four shelves, 4 levels of box files & 1 Locker W 900 x D 400 x H 2015  
 KD-036 Swing glass doors with four shelves, 5 levels of box files W 900 x D 400 x H 1850

### Features

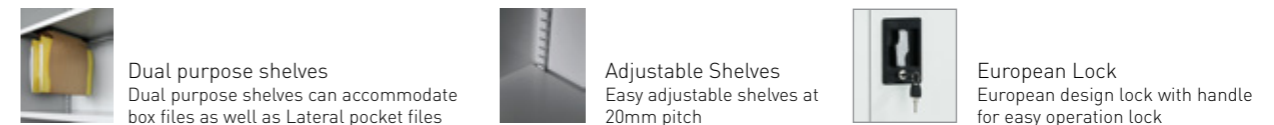

Dual purpose shelves Dual purpose shelves can accommodate box files as well as Lateral pocket files  
 Adjustable Shelves Easy adjustable shelves at 20mm pitch  
 European Lock European design lock with handle for easy operation lock

**FEATHERLITE OFFICE SYSTEMS (P) LTD.**

16/A, Millers Road, Vasanthnagar, Bangalore - 560 052.

**CUSTOMER CARE**

080 4719 1010

[sales@featherlitefurniture.com](mailto:sales@featherlitefurniture.com)

[www.featherlitefurniture.com](http://www.featherlitefurniture.com)

**Present in 66 locations**

across India, also in Nepal, Sri Lanka, and U.A.E.



ONLINE STORE



STORE LOCATOR



Wood from 3rd party certified for environmentally and socially responsible forestry management.