



*Featherlite*<sup>®</sup>

**CONTEMPO** RARY  
WORKSPACES CATALOGUE

VERSION: 01

# Change is the only constant

However, we are here to talk about the beginning of an evolution. An evolution of work culture driven by a sense of comfort and efficiency. In the midst of chaos and distractions. It is time to feel at home, at work.





## INDEX

About us	04
Design Thinking	08
Design Space	12
Genesis	22
Sofas	50
Lounge Chairs	92
High Chairs & Tables	106
Cafe Chairs	124
Tables	140
Nomad	168
Benches	176
Pouffes & Saddle	184
Laptop Tables	188
Tetris	192
Power Tower	198
Screens	200
Finishes	206

# Who we are

Incorporated in 1965 Featherlite is one of the leading furniture manufacturing organization in India today, providing complete office furniture solutions for all segments of the market through its strong base of direct and franchisee offices present across 62 locations in India.

Featherlite Core expertise lies in manufacturing and marketing extremely innovative, cost effective and customized office furniture such as modular work stations, chairs, partitions, desks, conference tables, educational, laboratory, retail furnitur, soft seating and fixtures.

	over <b>7 million</b> Chairs installed	
over <b>60 million</b> sqft of office space fitted across India		over <b>25,000</b> corporate customers across India
	over <b>1.2 million</b> Workstations installed	over <b>4.25 lakh</b> sqft of factory space

# Global Standards & Certifications

Featherlite is a member of BIFMA and is one of the leading Indian brands offering environmentally sustainable products as per ANSI/BIFMA e3-2014 standards. BIFMA compliance gives manufacturers, suppliers, architects, designers and government agencies a benchmark for production of sustainable office / institutional furniture and seating products. This mark establishes performance criteria that address environmental, economic and social aspects throughout the supply chain.

Our commitment is towards creating **high quality & environmentally sustainable** products



Green Guard Gold certification from UL Environment indicates that matrial process or finished product meets extremely rigorous standards for low emission of volatile organic compunds (VOCs)

# 100% Solar

Featherlite, besides being a leading Furniture Manufacturer in India is also a responsible Corporate Citizen. The Company is one of the first manufacturing unit in the state of Karnataka to not only sign an MOU with the State Government but also to implement and generate 1 MW Solar Rooftop Photovoltaic system (SRTPV) on an industrial building.

The "State of the Art" manufacturing unit located at Hejjala, 20km from Bangalore has a rooftop area of 1 Lakh sq. ft. The Company has utilized every available roof space including canteen, two wheeler stand, car parking roof and canopies besides the main manufacturing unit in order to maximize the power generation & generates over 1MW of Solar Power.

A total number of 3,000 solar panels each generating 320Wp of power per day and 16 string invertors support the power generation and transmission to Power Receiving Yard. The system has been integrated with state power supply board and surplus power generated is fed into the grid. The system will produce 1.5 million units per annum of which 0.5 million units will be fed into the grid lighting scores of house holds. This major initiative by the company has reaffirmed Group's commitment to minimizing environment degradation by reducing Carbon Footprint and helping the Government to achieve "Electricity for All" by 2020 goal set by the Prime Minister.



# Major Clients



and thousands more

# Design Thinking

Design thinking is a process for solving problems by prioritizing the consumer's needs above all else.

It relies on observing, with empathy, how people interact with their environments, and employs an iterative, hands-on approach to creating innovative solutions.

Design thinking is "human-centered," which means that it uses evidence of how consumers (humans) actually engage with a product or service, rather than how someone else or an organization thinks they will engage with it.

This is the "iterative" part of design thinking. It favors moving quickly to get prototypes out to test, rather than endless research or rumination.

In contrast to traditional problem-solving, which is a linear process of identifying a problem and then brainstorming solutions, design thinking only works if it is iterative.





## Empathize

### Understanding People

In this first stage, the designer observes consumers to gain a deeper understanding of how they interact with or are affected by a product or issue. The observations must happen with empathy, which means withholding judgment and not imparting preconceived notions of what the consumer needs. Observing with empathy is powerful because it can uncover issues the consumer didn't even know they had or that they could not themselves verbalize. From this point, it's easier to understand the human need for which you are designing.

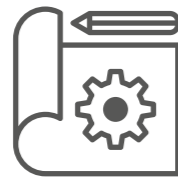

## Prototype

### Creation & Experimentation

This is the stage that turns ideas into an actual solution. Prototypes are not meant to be perfect. The point of a prototype is to come out quickly with a concrete version of the idea to see how it is accepted by consumers. Examples of prototypes include a landing page to test consumer desire for a product or a video that demonstrates streamlined logistic processes.



## Define

### Figuring out the problem

In this second stage, you gather your observations from the first stage to define the problem you're trying to solve. Think about the difficulties your consumers are brushing up against, what they repeatedly struggle with, and what you've gleaned from how they're affected by the issue. Once you synthesize your findings, you are able to define the problem they face.

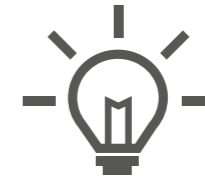

## Ideate

### Generating Your Ideas

The next step is to brainstorm ideas about how to solve the problem you've identified. These ideation sessions could be in a group, where your team gathers in an office space that encourages creativity and collaboration, an innovation lab, or can be done solo. The important part is to generate a bunch of different ideas. At the end of this process, you'll come up with a few ideas with which to move forward.



## Test

### Redefining the Product

Once you give a prototyped solution to consumers, you must observe how they interact with it. This testing stage is the one in which you collect feedback on your work.

The design-thinking process is an iterative, rather than linear, one. At the end of the fifth stage, you'll likely have to go back to one or several of the other stages. Perhaps the testing has shown you need to develop another prototype, for which you'd return to the fourth stage. Or perhaps it's shown that you've misdefined the consumer's needs. If so, you would have to return to an earlier stage of the process.

# Space Ideas

At Featherlite,  
we convert open empty spaces into productive workspaces.

Through our products, we create areas which encourage collaboration and communication amongst teams, as well as focus and creativity when working alone.

We ensure you get maximum efficiency from your available office space.



# Collaboration Space





# Learning Space



# Personal Space



# Social Space



# Genesis

Genesis is a gateway to the elements of productivity. It is the convergence of privacy, focus and collaboration. Intimate yet open, this space respects individuality while strengthening team work. The Genesis design approach is one of duality, a demonstration of harmony between key standards - body and space, straightforward and inconspicuous, relentless yet delicate, cozy yet open.

We've chosen the materials used to make Genesis with extraordinary consideration. Subsequently, the peaceful structure reflects both the effortless and power contained within our idea.

# 01

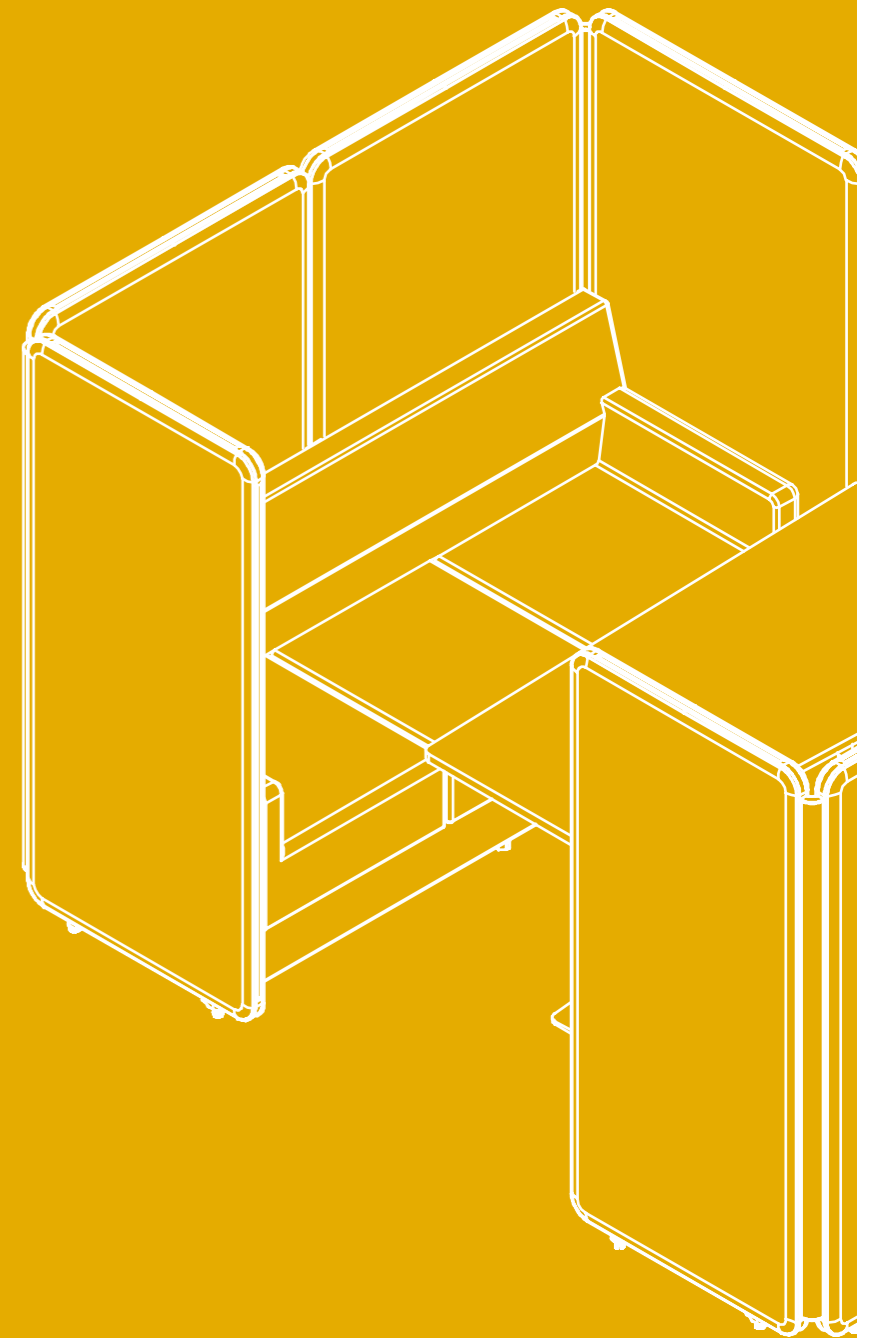

# POD

The Genesis POD creates a bohemian environment and a casual perception of a work environment while catalysing employee efficiency and productivity. It is a micro office that is less expensive than traditional offices, allowing more people to fit into a smaller space.

3 seater comfortable sofas on either side of a centre table are enclosed by specially designed sound absorbing acoustic walls. The POD is fitted with multiple charging points making it an ideal discussion or conference space that utilises light and ventilation from its surroundings.



## TECHNICAL DETAILS

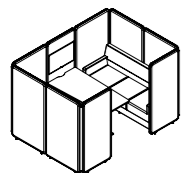

3+3 Seater  
L 2700 x W 1900 x H 1650 mm

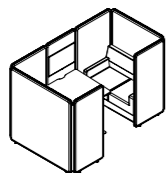

2+2 Seater  
L 2700 x W 1350 x H 1650 mm

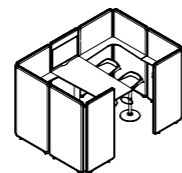

With High Desk  
L 2700 x W 1350 x H 1650 mm

### NOTE:

1. Aluminium extrusions comes with anodised finish.
2. Select one colour of fabric for inner and one colour for outer body panels.

# WORK POD



## TECHNICAL DETAILS

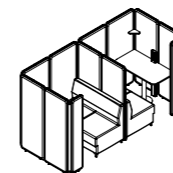

2+2 Seater  
L 2980 x W 1320 x H 1650 mm

### NOTE:

1. Aluminium extrusions comes with anodised finish.
2. Select one colour of fabric for inner and one colour for outer body panels.

# POD

SEMI CLOSED



with Back Panel



without Back Panel

## TECHNICAL DETAILS

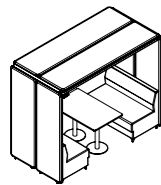

2+2 Seater  
L 2700 x W 1350 x H 2150 mm

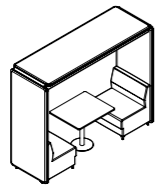

1+1 Seater  
L 2700 x W 900 x H 2150 mm

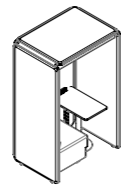

Single Seater  
L 1320 x W 900 x H 2150 mm

NOTE:

- 1. Aluminium extrusions comes with anodised finish.
- 2. Select one colour of fabric for inner and one colour for outer body panels.

# SHARING POD

SEMI CLOSED



## TECHNICAL DETAILS

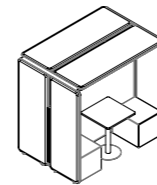

4 Seater Sharing  
L 1920 x W 1350 x H 1820 mm

NOTE:

- 1. Aluminium extrusions comes with anodised finish.
- 2. Select one colour of fabric for inner and one colour for outer body panels.

SalesForce



# PHONE BOOTH

The Genesis Telephone Booth can turn any space into a private enclosure. It captures an insulated bubble of peace without the burden of difficult installation or renovation. Built in with plug and play electrical connections it allows office workers to stay within their work space and attend phone calls with the desired level of privacy.

With an extended table top, in built plug and play features and a backrest to lean on, the Booth is a one stop shop for those looking for private zones in an open air or indoor office environment.



## TECHNICAL DETAILS

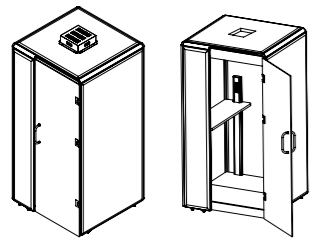

Booth  
L 1200 x W 1200 x H 2100 mm

Shelf  
L 1050 x W 350 x H 25 mm

### NOTE:

1. Aluminium extrusions comes with anodised finish.
2. Select one colour of fabric for inner and one colour for outer body panels.

Samsung

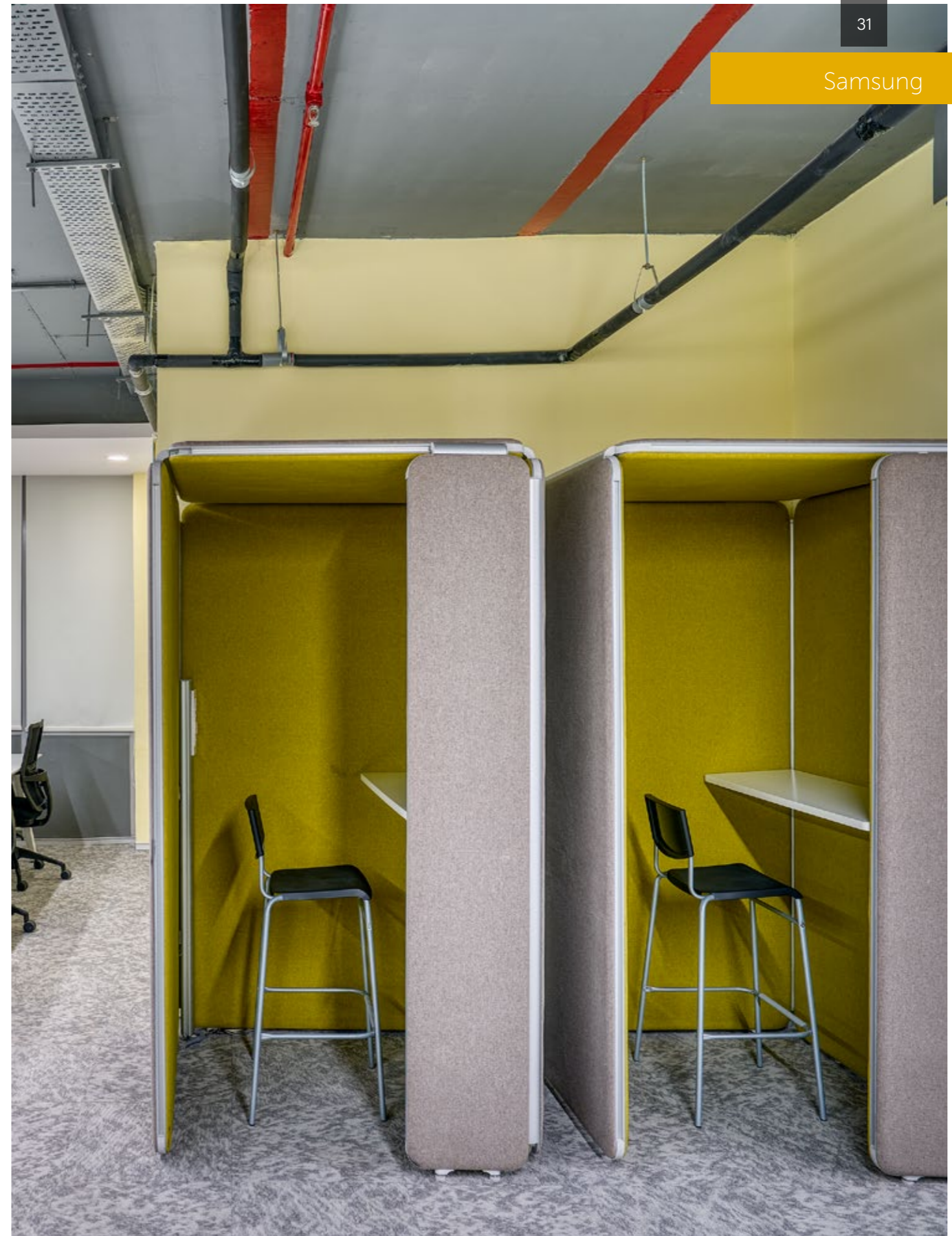



# INTERACT

In organisations all across the world, coordinated effort has become the biggest catalyst for advancement and development. Genesis Interact is a perfect fit for an open workspace, with frosted acrylic screens that allow privacy and collaboration to go hand in hand creating an optimal and vibrant focus zone to help employees innovate faster, achieve better results and report higher job satisfaction.



## TECHNICAL DETAILS

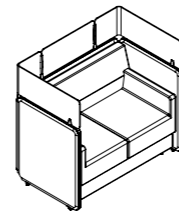

2+2 Seater With Screen  
L 1300 x W 800 x H 1200 mm

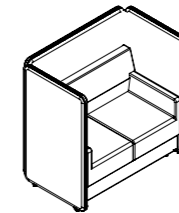

2+2 Seater Without Screen  
L 1300 x W 800 x H 1200 mm

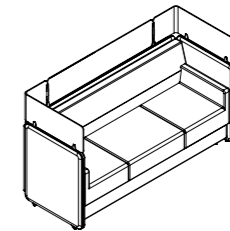

3+3 Seater With & Without Screen  
L 1920 x W 800 x H 1200 mm

### NOTE:

1. Aluminium extrusions comes with anodised finish.
2. Select one colour of fabric for inner and one colour for outer body panels.
3. Fabric colour of sofa is always same as of outer body of panels.

# MEDIASCAPE

Find unlimited possibilities and forward-thinking design in Genesis Mediascape, which you can configure exactly the way you need it. It allows you to create a tailor made collaborative space in which people are free to circulate and interact in different settings.

Genesis Mediascape incorporates innovation and furniture to bring individuals, space and data together for a greater collaborative work environment and more productivity.



## TECHNICAL DETAILS

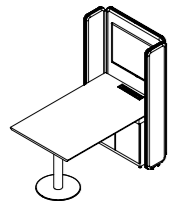

Standard Height (With Storage)

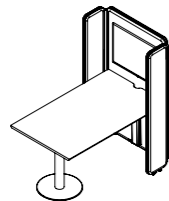

Standard Height (Without Storage)

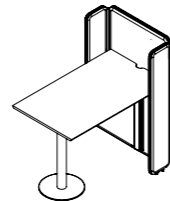

With High Desk (With & Without Storage)

Mediascape: L 1560 x W 1000 x H 1650 mm | Table: L 900 x W 1500 x H 750/1000 mm | Storage: L 750 x W 250 x H 725/975 mm

NOTE:

1. Aluminium extrusions comes with anodised finish.
2. Select one colour of fabric for inner and one colour for outer body panels.

# RECHARGE

Genesis Recharge is a private workspace that is intended to be useful for your body and for your mind – giving spots to get away without moving ceaselessly. It is a great fit for modern open space solutions, especially when task oriented work environments are combined with areas that are equipped for specific tasks.

With the right amount of visual privacy, a built in power supply teamed with a support platform for notebooks & laptops, the Genesis Recharge meets th employee’s needs in a modern work space that makes you feel at home, at work.



## TECHNICAL DETAILS

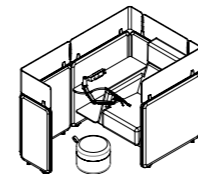

With Return Panel (With Screen)  
L 1200 x W 1800 x H 1200 mm

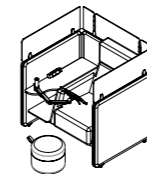

Without Return Panel (With Screen)  
L 1200 x W 950 x H 1200 mm

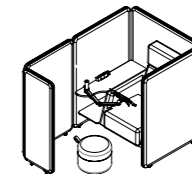

With Return Panel (Without Screen)  
L 1200 x W 1800 x H 1200 mm

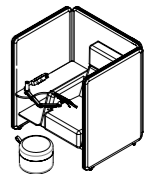

Without Return Panel (Without Screen)  
L 1200 x W 950 x H 1200 mm

NOTE:

1. Aluminium extrusions comes with anodised finish.
2. Select one colour of fabric for inner and one colour for outer body panels.
3. Fabric colour of sofa is always same as of outer body of panels.
4. Leg rest comes with dual colours selected for inner/outer panels.



# i-WORK

iWork is a high-performing private workstation planned explicitly for the in between spaces in corporate environments. As dedicated touchdown spaces for employees in open-plan workplaces iWork gives individuals moments of focus in high-traffic settings.

A room-in-room solution with the main features such as ventilation, visual privacy ease of assembly and the possibility to move the unit in a mounted state allows iWork to make an overall difference in employee performance and well being.



## TECHNICAL DETAILS

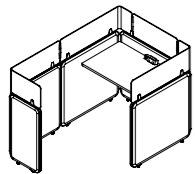

With Return Panel  
(With Screen)  
L 1200 x W 1800 x H 1200 mm

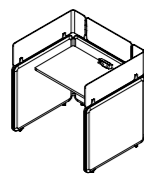

Without Return Panel  
(With Screen)  
L 1200 x W 950 x H 1200 mm

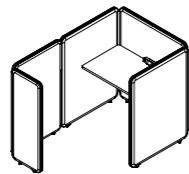

With Return Panel  
(Without Screen)  
L 1200 x W 1800 x H 1200 mm

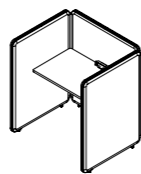

Without Return Panel  
(Without Screen)  
L 1200 x W 950 x H 1200 mm

### NOTE:

1. Aluminium extrusions comes with anodised finish.
2. Select one colour of fabric for inner and one colour for outer body panels.

# PORTAL

Today's workers must be creative problem-solvers. The Portal privacy pod meets workers' diverse needs for collaboration, privacy, focus and regeneration in a whole new way. With creativity front and center in the work people are doing today, spaces like Portal that optimize the creative output of teams and individuals are increasingly important. The creative process isn't limited to large group brainstorming and open plan collaboration – having access to spaces for focus work or smaller, uninterrupted conversations is just as crucial to unleashing a team's full creative potential.



## TECHNICAL DETAILS

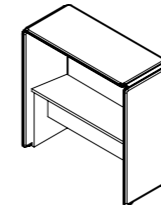

Pod: L 2130 x W 900 x H 2130 mm  
Table: L 2010 x W 600 x H 1100 mm

### NOTE:

1. Aluminium extrusions comes with anodised finish.
2. Select one colour of fabric for inner and one colour for outer body panels.

# ARENA

The Arena is a spectacle of ergonomic design and provides multi functionality. Employees have the option of using it not only for collaboration but also individual focused work. There are desk spaces fitted on to the back of the Arena which makes it an additional work area. With electrical supplies for charging devices and Ethernet ports for internet connectivity, the Arena is a complete office furniture design that can help catalyze collaboration and grow employee productivity.

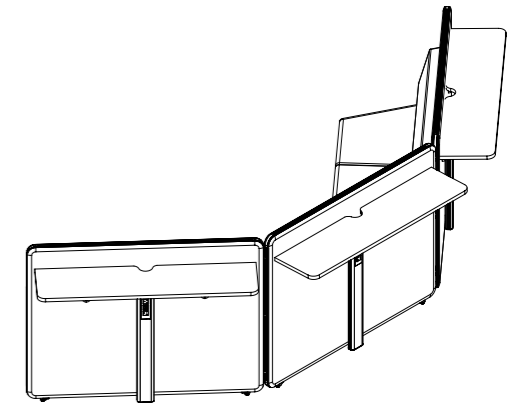

6+6 SEATER ARENA

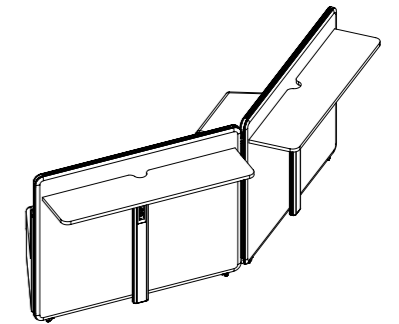

4+4 SEATER ARENA

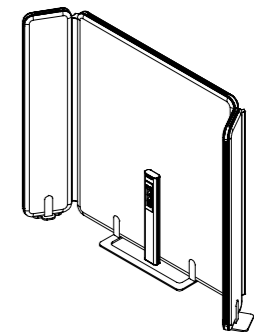

MEDIA UNIT



## TECHNICAL DETAILS

6+6 Seater Arena	L 4500 x W 1750 x H 1200 mm
4+4 Seater Arena	L 2965 x W 1390 x H 1200 mm
Media Unit Dimensions	L 1860 x W 460 x H 1500 mm

### NOTE:

1. Aluminium extrusions comes with anodised finish.
2. Select one colour of fabric for inner and one colour for outer body panels.



# MULTIPLY

Multiply is based on the concept of functional geometry. The trifecta shape allows you to multiply space utilisation by having 3 exposed sides, each with its own purpose and sheltered from visual and sonic disturbances on all sides.

An average employee has a third less space in their office than they did a decade ago. Genesis Multiply lets you fit more people into smaller task specific spaces.



## TECHNICAL DETAILS

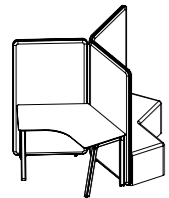

L 1900 x W 1900 x H 1650 mm

NOTE:  
1. Aluminium extrusions comes with anodised finish.

# STUDY



## TECHNICAL DETAILS

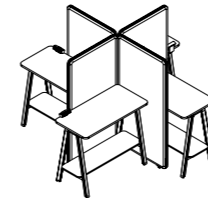

Screen (LxH) : 900 x 1650 mm | Table (LxWxH) : 1200 x 600 x 1050 mm

NOTE:  
1. Aluminium extrusions comes with anodised finish.

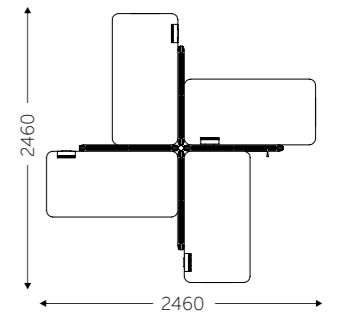

# REFLECT

Designed for today's inclusive, flexible workplace, Genesis Reflect was born out of the realisation that teamwork and collaborative events are intrinsic to the success of the world's top companies.

With a straight forward mirror image design, Reflect serves as a new kind of seating for casual work environments, where employees can relax and rejuvenate, kill time between appointments, and above all feel at ease.



## TECHNICAL DETAILS

Reflect Dimensions (LxWxH)	2000 x 1360 x 900 mm
Table Top Dimensions	650 x 550 x 40 mm

### NOTE:

1. Aluminium extrusions comes with anodised finish.
2. Select one colour of fabric for inner and one colour for outer body panels.





# HONEY COMB

Honey Comb is your perfect noise barrier, acoustically enhanced to separate you from the hubbub of the workplace. Honeycomb is designed to create a sense of privacy in one's own nest, while still being in close contact with teammates around.

With numerous configurations available and a degree of tech-savviness, Honey Comb supports not only your work style but also varying IT needs. Honey Comb's wire accesses, data connectivity, and acoustic properties make it the ideal work retreat.



## TECHNICAL DETAILS

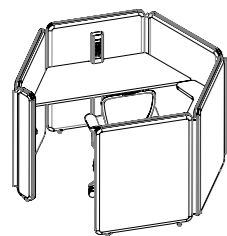

L 1722 x W 1722 x H 1200 mm



### NOTE:

1. Aluminium extrusions comes with anodised finish.
2. Select one colour of fabric for inner and one colour for outer body panels.

# REFLEX

Perfectly suited for social and relaxation spaces, the Reflex sofas are a stylish design choice for the centre of any space. With the ability to hold up to 2 people on each sofa, Reflex creates a sense of privacy while also creating a sense of togetherness for the occupants.

With up to three different colour combinations, Reflex adds a touch of vibrancy and brightness to any office space.

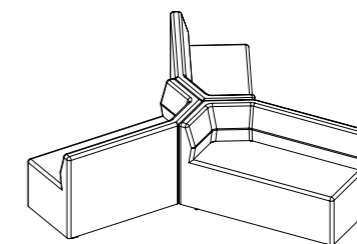

L 2800 x W 2350 x H 860 mm

# Sofas

Sofas are one of the many first impressions for customers and clients when visiting a space. Contemporary Sofa Designs reflect the character of the company and the people within the enterprise.

Featherlite Sofas boast comfortable and enveloping design features with a light structure and a contemporary padded seat that ensures to be suitable in both modern and traditional design environments.

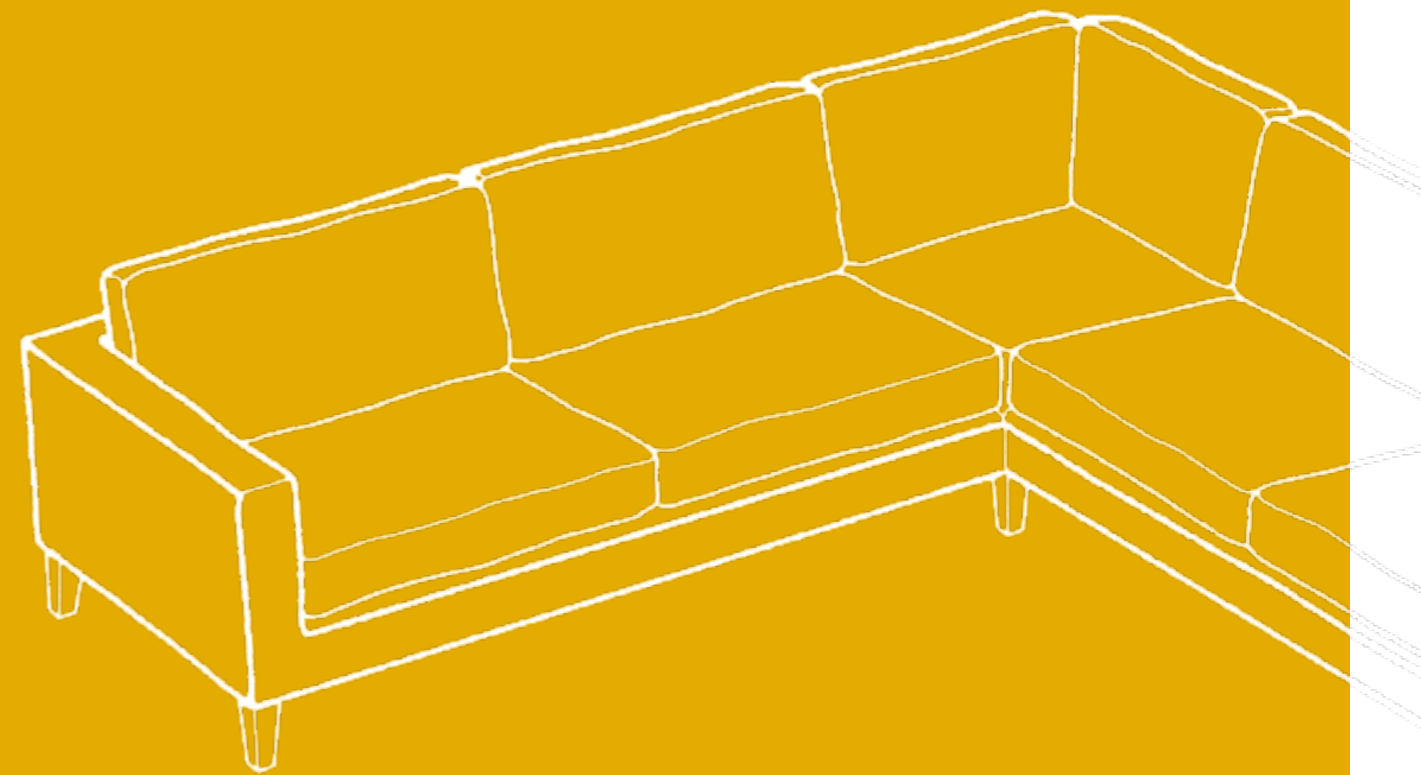

# 02

# OMEGA 1



## TECHNICAL DETAILS

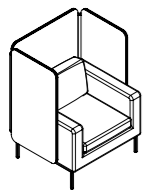

Single Seater  
L 900 x D 815 x H 1200 mm

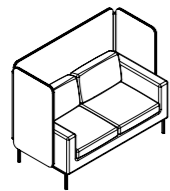

Two Seater  
L 1500 x D 815 x H 1200 mm

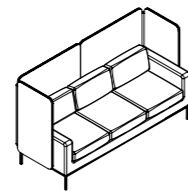

Three Seater  
L 2100 x D 815 x H 1200 mm

### NOTE:

1. Aluminium extrusions comes with anodised finish.



# OMEGA 2



With work table and power management

## TECHNICAL DETAILS

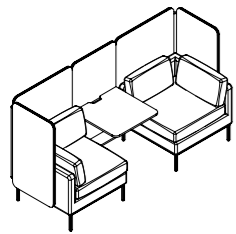

L 2275 x D 815 x H 1200

NOTE:

1. Aluminium extrusions comes with anodised finish.

# OMEGA 3



With centre table and power management

## TECHNICAL DETAILS

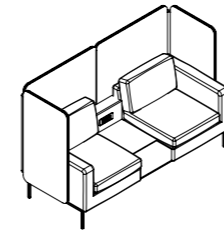

L 1900 x D 815 x H 1200 mm

NOTE:

1. Aluminium extrusions comes with anodised finish.

# S SERIES



## Single Seater

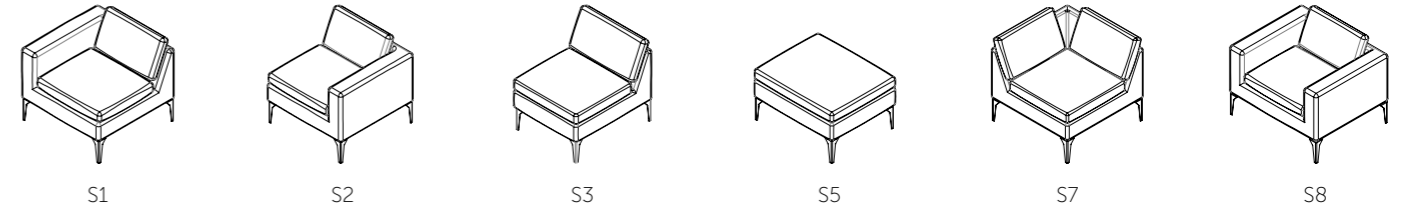

## Two Seater

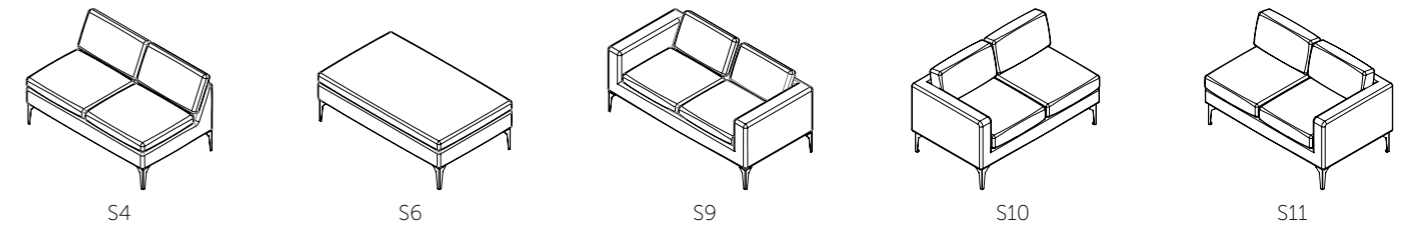

## Two & Half Seater

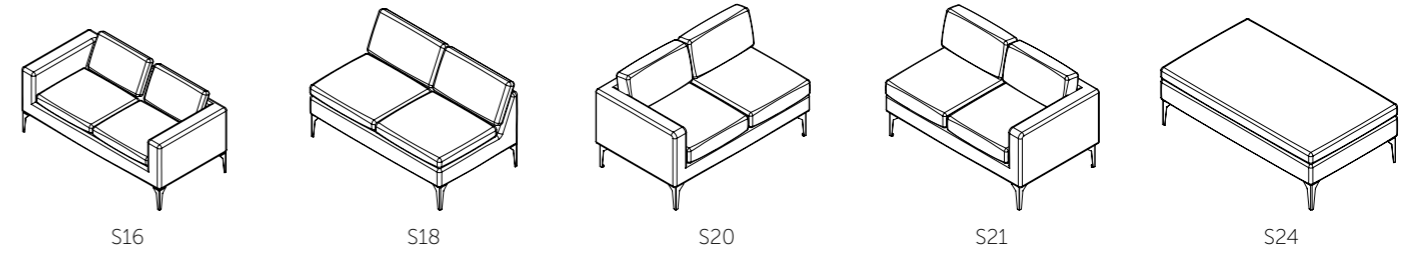

## Three Seater

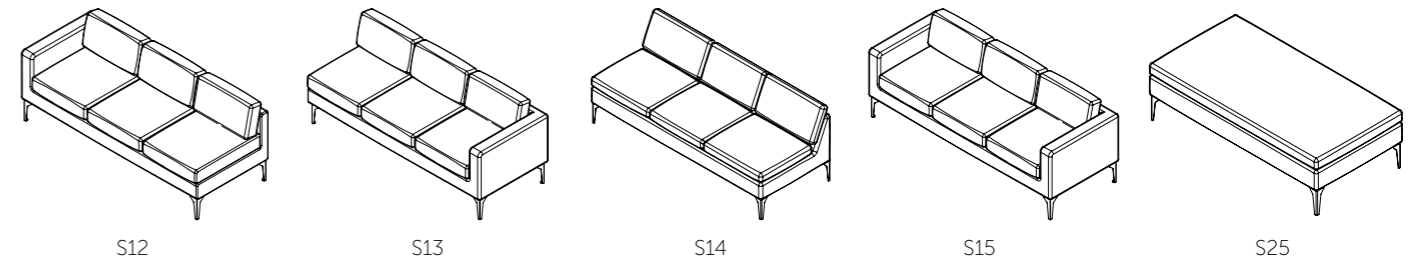

## Three & Half Seater

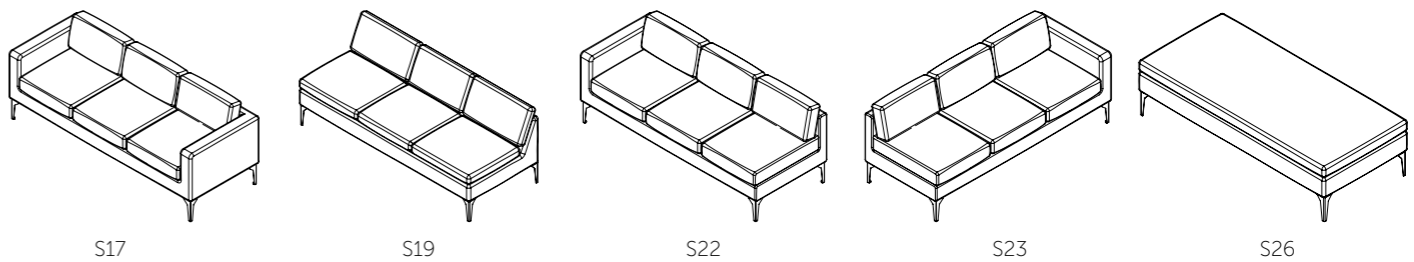

## TECHNICAL DETAILS

Metal Powder Coated

S1: L 725 x D 790 x H 790  
 S2: L 725 x D 790 x H 790  
 S3: L 600 x D 790 x H 790  
 S4: L 1200 x D 790 x H 790  
 S5: L 600 x D 550 x H 450  
 S6: L 1200 x D 550 x H 450  
 S7: L 790 x D 790 x H 790

S8: L 850 x D 790 x H 790  
 S9: L 1450 x D 790 x H 790  
 S10: L 1325 x D 790 x H 790  
 S11: L 1325 x D 790 x H 790  
 S12: L 1925 x D 790 x H 790  
 S13: L 1925 x D 790 x H 790  
 S14: L 1800 x D 790 x H 790

S15: L 2050 x D 790 x H 790  
 S16: L 1750 x D 790 x H 790  
 S17: L 2350 x D 790 x H 790  
 S18: L 1500 x D 790 x H 790  
 S19: L 2100 x D 790 x H 790  
 S20: L 1625 x D 790 x H 790

S21: L 1625 x D 790 x H 790  
 S22: L 2225 x D 790 x H 790  
 S23: L 2225 x D 790 x H 790  
 S24: L 1500 x D 550 x H 450  
 S25: L 1800 x D 550 x H 450  
 S26: L 2100 x D 550 x H 450

# S SERIES





# GENESIS SOFA WITH ARMS



# GENESIS SOFA WITHOUT ARMS



## TECHNICAL DETAILS

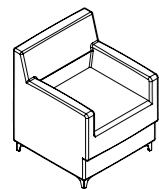

Single Seater  
L 700 x D 725 x H 860

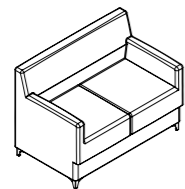

Two Seater  
L 1200 x D 725 x H 860

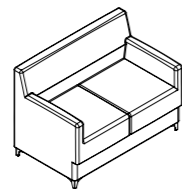

Two & Half Seater  
L 1500 x D 725 x H 860

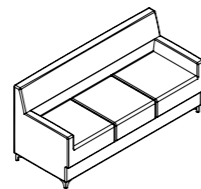

Three Seater  
L 1800 x D 725 x H 860

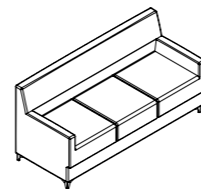

Three & Half Seater  
L 2100 x D 725 x H 860

## TECHNICAL DETAILS

Metal Powder Coated

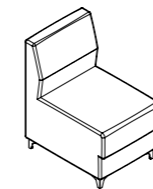

Single Seater  
L 530 x D 725 x H 860

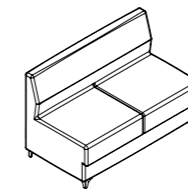

Two Seater  
L 1060 x D 725 x H 860

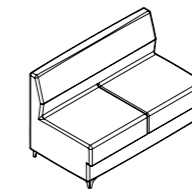

Two & Half Seater  
L 1360 x D 725 x H 860

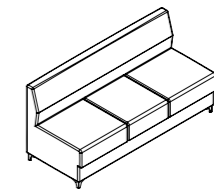

Three Seater  
L 1590 x D 725 x H 860

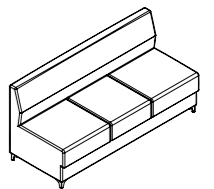

Three & Half Seater  
L 1890 x D 725 x H 860



# M SERIES

METAL POWDER COATED LEGS



# W SERIES

SOLID WOOD LEGS



## TECHNICAL DETAILS

Metal Powder Coated Legs

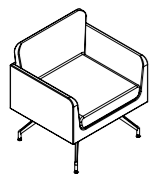

Single Seater  
L 700 x D 665 x H 780

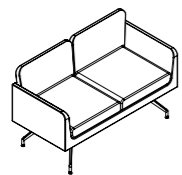

Two Seater  
L 1200 x D 665 x H 780

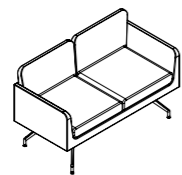

Two & Half Seater  
L 1500 x D 665 x H 780

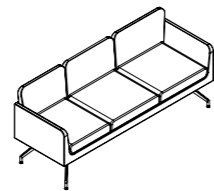

Three Seater  
L 1800 x D 665 x H 780

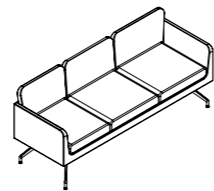

Three & Half Seater  
L 2100 x D 665 x H 780

## TECHNICAL DETAILS

Solid Wood Legs

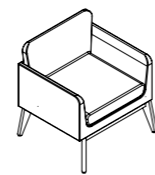

Single Seater  
L 700 x D 665 x H 780

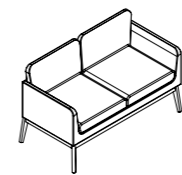

Two Seater  
L 1200 x D 665 x H 780

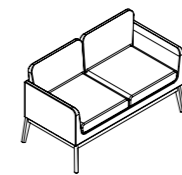

Two & Half Seater  
L 1500 x D 665 x H 780

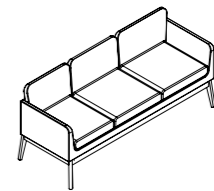

Three Seater  
L 1800 x D 665 x H 780

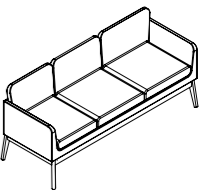

Three & Half Seater  
L 2100 x D 600 x H 780

# F SERIES

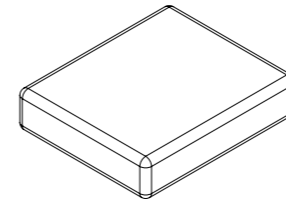

F1  
L 600 x D 675 x H 150

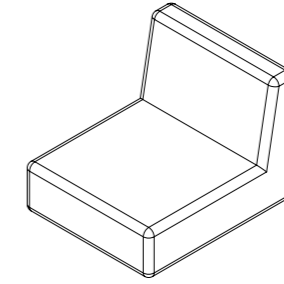

F2  
L 600 x D 675 x H 450

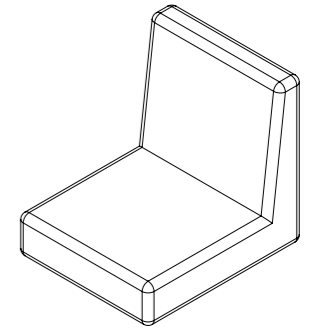

F3  
L 600 x D 675 x H 600

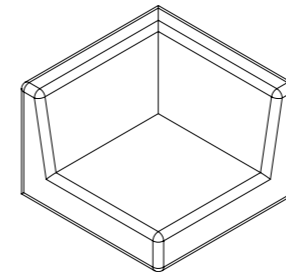

F4  
L 675 x D 675 x H 450

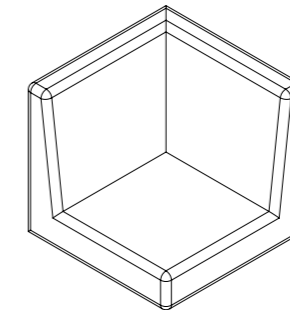

F5  
L 675 x D 675 x H 600

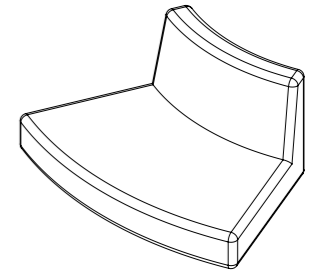

F6  
L 1060 x D 675 x H 450

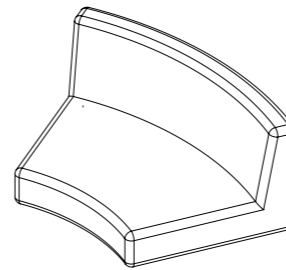

F7  
L 1060 x D 675 x H 450

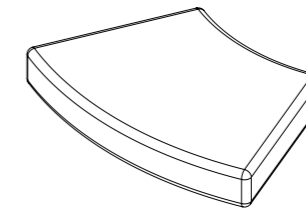

F8  
L 1060 x D 675 x H 150

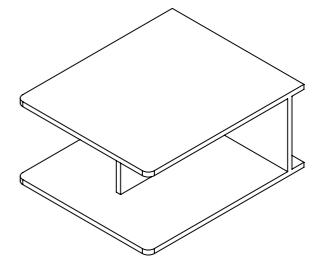

F9  
L 600 x D 675 x H 300

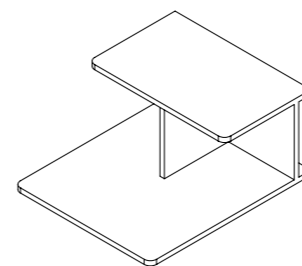

F10  
L 600 x D 675 x H 300

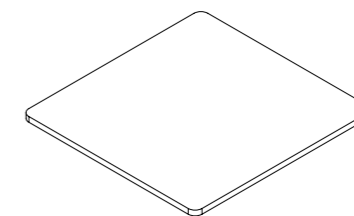

F11  
L 600 x D 675 x 18mm Thickness

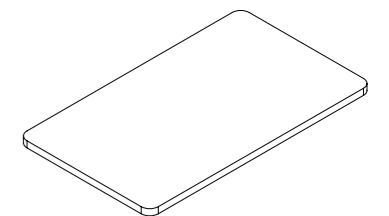

F12  
L 300 x D 675 x 18mm Thickness

# F SERIES



## TECHNICAL DETAILS

Metal Powder Coated Legs

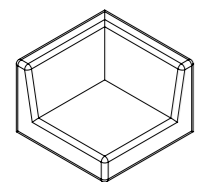

F4 (x1)  
L 675 x D 675 x H 450

+

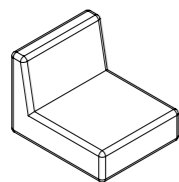

F2 (x2)  
L 600 x D 675 x H 450

+

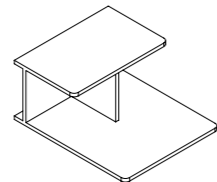

F10 (x1)  
L 600 x D 675 x H 300

+

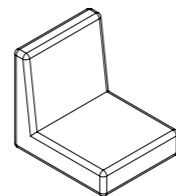

F3 (x2)  
L 600 x D 675 x H 600

+

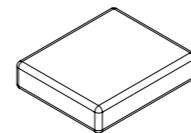

F1 (x1)  
L 600 x D 675 x H 150

+

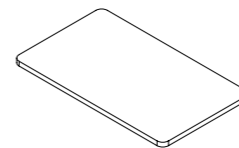

F12 (x1)  
L 300 x D 675 x H 18mm Thickness

# F SERIES



## TECHNICAL DETAILS

Metal Powder Coated Legs

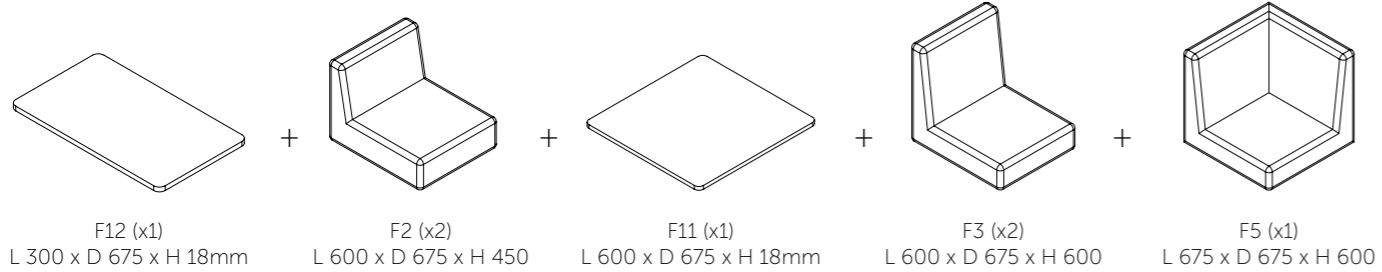

# F SERIES



## TECHNICAL DETAILS

Metal Powder Coated Legs

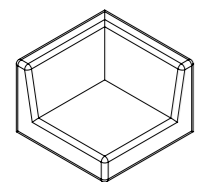

F4 (x4)  
L 675 x D 675 x H 450

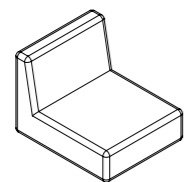

F2 (x8)  
L 600 x D 675 x H 450

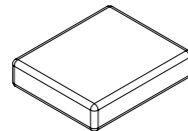

F1 (x1)  
L 600 x D 675 x H 150

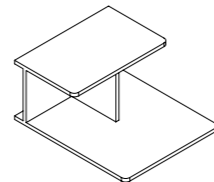

F10 (x1)  
L 600 x D 675 x H 300



## TECHNICAL DETAILS

Metal Powder Coated Legs

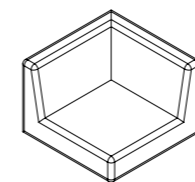

F4 (x2)  
L 675 x D 675 x H 450

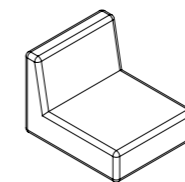

F2 (x2)  
L 600 x D 675 x H 450

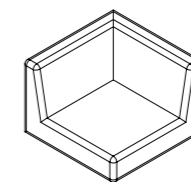

F4 (x4)  
L 675 x D 675 x H 450

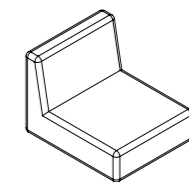

F2 (x6)  
L 600 x D 675 x H 450

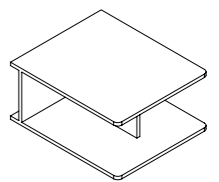

F9 (x2)  
L 600 x D 675 x H 300

# F SERIES



## TECHNICAL DETAILS

Metal Powder Coated Legs

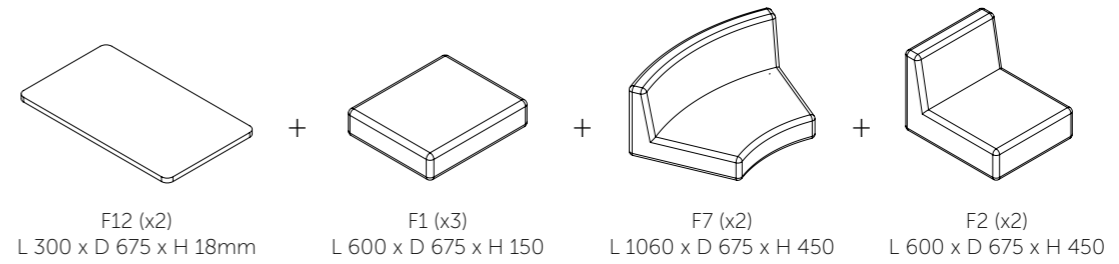

## TECHNICAL DETAILS

Metal Powder Coated Legs

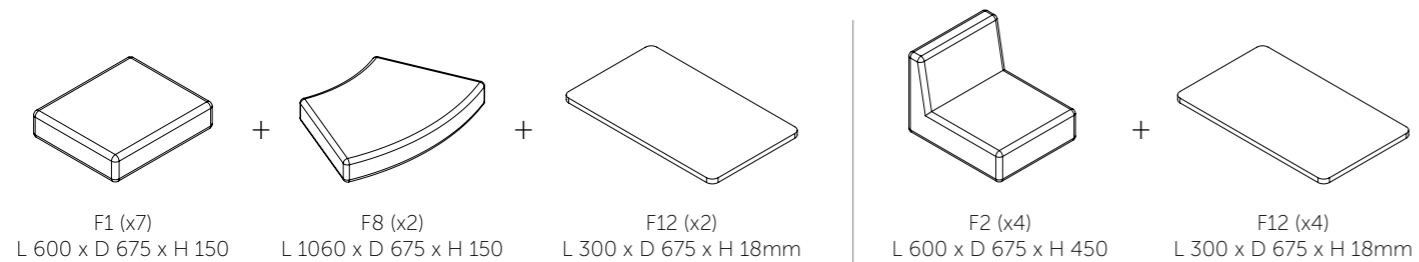

## TECHNICAL DETAILS

Metal Powder Coated Legs

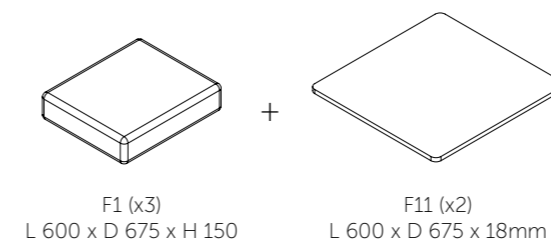

# F SERIES



## TECHNICAL DETAILS

Metal Powder Coated Legs

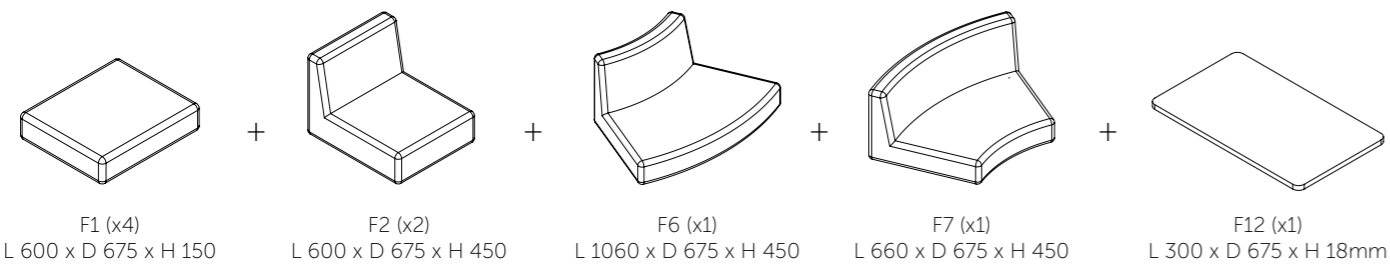

## TECHNICAL DETAILS

Metal Powder Coated Legs

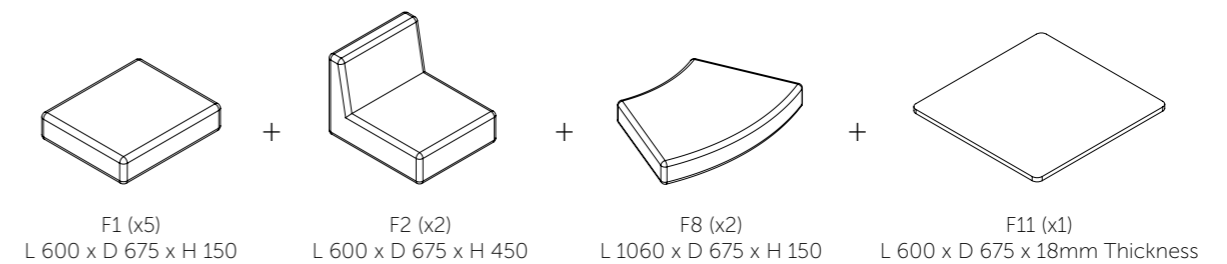

# F SERIES



## TECHNICAL DETAILS

Metal Powder Coated Legs

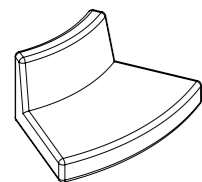

F6 (x8)  
L 1060 x D 675 x H 450

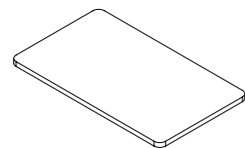

F12 (x2)  
L 300 x D 675 x H 18mm

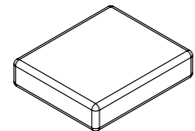

F1 (x2)  
L 600 x D 675 x H 150

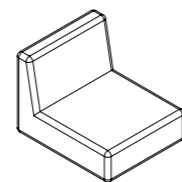

F2 (x4)  
L 600 x D 675 x H 450

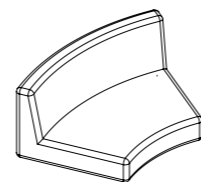

F7 (x4)  
L 660 x D 675 x H 450

## TECHNICAL DETAILS

Metal Powder Coated Legs

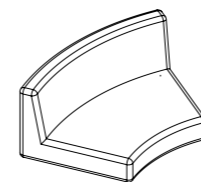

F7 (x6)  
L 660 x D 675 x H 450

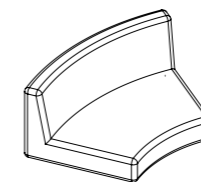

F7 (x4)  
L 660 x D 675 x H 450

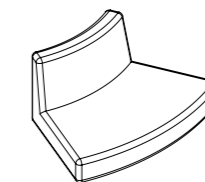

F6 (x4)  
L 1060 x D 675 x H 450



# F SERIES



## PEARL LEATHERETTE / FABRIC



**1 Seater:** 810 (L) x 720 (D) X 685 (H) | **2 Seater:** 1320 (L) x 720 (D) X 685 (H) | **3 Seater:** 1855 (L) x 720 (D) X 685 (H)  
Legs: Steel & Chrome

## CONVERSE LEATHERETTE / FABRIC



**1 Seater:** 890 (L) x 800 (D) X 820 (H) | **2 Seater:** 1390 (L) x 800 (D) X 820 (H) | **3 Seater:** 1930 (L) x 800 (D) X 820 (H)  
Legs: Steel & Chrome

## INTERACT LEATHERETTE / FABRIC



**1 Seater:** 770 (L) x 750 (D) X 740 (H) | **2 Seater:** 1280 (L) x 750 (D) X 740 (H) | **3 Seater:** 1830 (L) x 750 (D) X 740 (H)  
Legs: Steel & Chrome

## INDULGE LEATHERETTE / FABRIC



**1 Seater:** 770 (L) x 750 (D) X 740 (H) | **2 Seater:** 1280 (L) x 750 (D) X 740 (H) | **3 Seater:** 1830 (L) x 750 (D) X 740 (H)  
Legs: Steel & Chrome

# CONCAVE



## TECHNICAL DETAILS

Metal Powder Coated

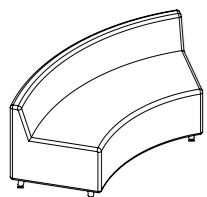

Concave Single  
Outer R 1650 / Inner R 1000 x D 650 x H 750 mm

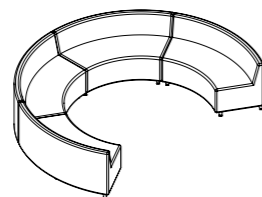

Semi Circle  
Outer Dia 3300 / Inner Dia 2000 x D 650 x H 750 mm

# CONCAVE 2P



## TECHNICAL DETAILS

Metal Powder Coated

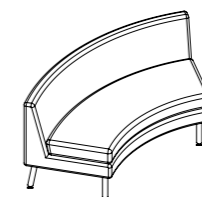

Concave 2P Single  
Outer R 1650 / Inner R 1000 x D 650 x H 750 mm



# CONVEX



## TECHNICAL DETAILS

Metal Powder Coated

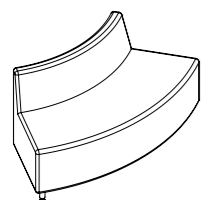

Convex  
Outer R 1650 / Inner R 1000 x D 650 x H 750 mm

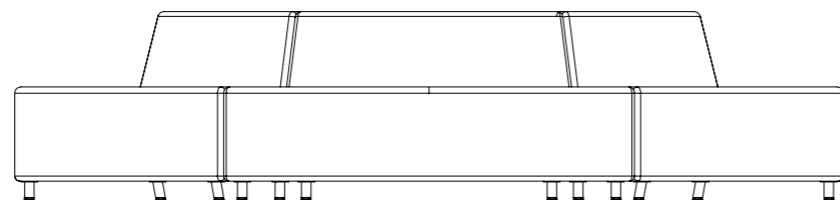

Circular  
Outer Dia 3300 / Inner Dia 2000 x D 650 x H 750 mm

# CONVEX 2P



## TECHNICAL DETAILS

Metal Powder Coated

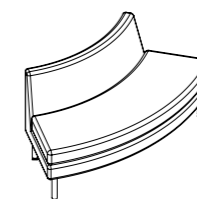

Convex 2P Single  
Outer R 1650 / Inner R 1000 x D 650 x H 750 mm

# S SHAPE



## TECHNICAL DETAILS

Metal Powder Coated

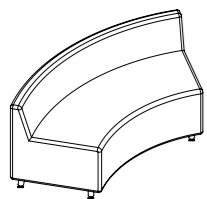

Concave  
Outer R 1650 / Inner R 1000 x D 650 x H 750 mm

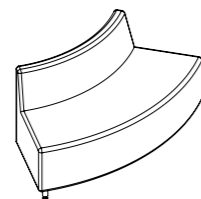

Convex  
Outer R 1650 / Inner R 1000 x D 650 x H 750 mm

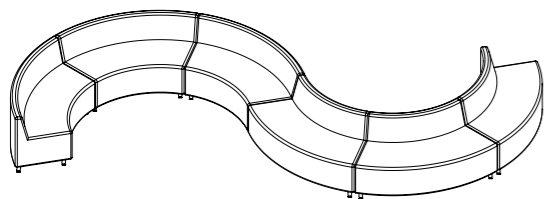

S Shape 6 Piece  
L 5140 x D 4625 x H 750 m

# SEMI CIRCULAR



## TECHNICAL DETAILS

Metal Powder Coated

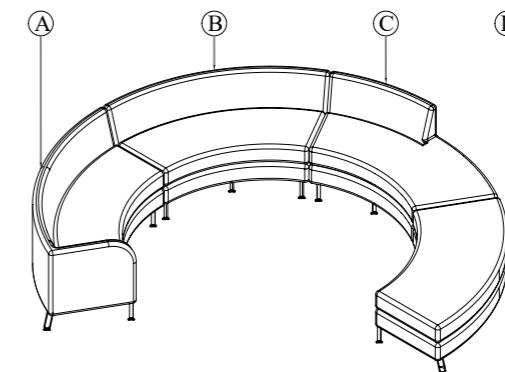

A: With back rest & Armrest | B: With Back rest | C: With half back rest | D: Without back rest

Single Sofa

Outer R 1650 / Inner R 1000 x D 650 x H 750 mm (with back rest) / W.O. back rest H 450 mm

Semi Circular Sofa

Outer Dia 3300 / Inner Dia 2000 x D 3170 x H 750 mm

# Lounge Chairs

One of the most important aspects of running a business is creating a comfortable environment for customers.

Our office lounge chairs are created with the goal of comfort in mind. Whether it be for the waiting spaces, or even the lounge and meeting spaces, our soft seating keeps ergonomics and posture in mind, while maintaining a contemporary appeal by adding a burst of colour to your office space.



# 03

# FLORA

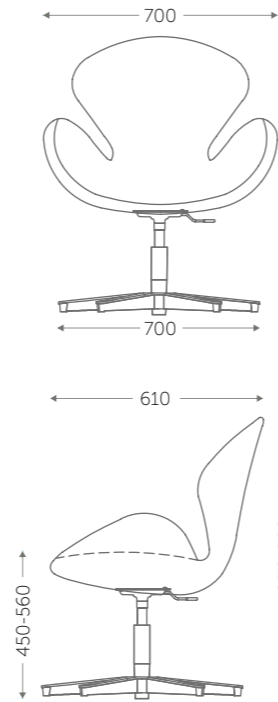

# COSTA

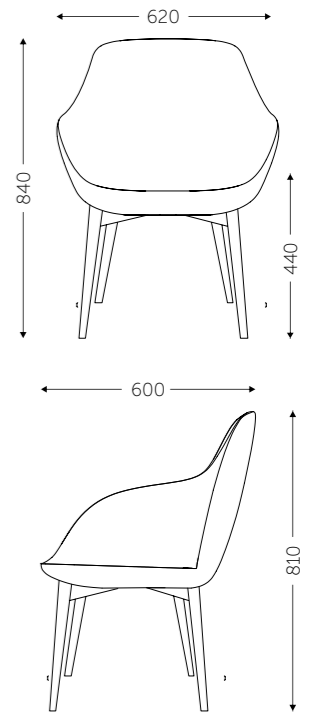

# ARCTIC

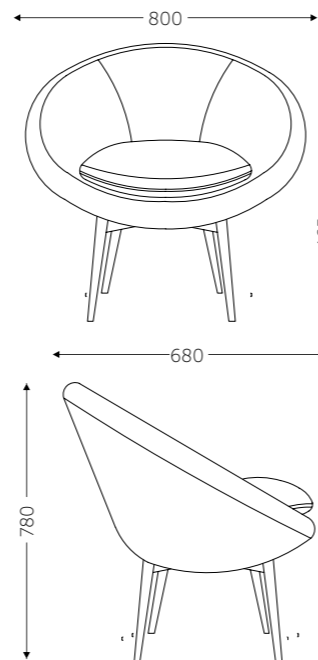

# CLARA

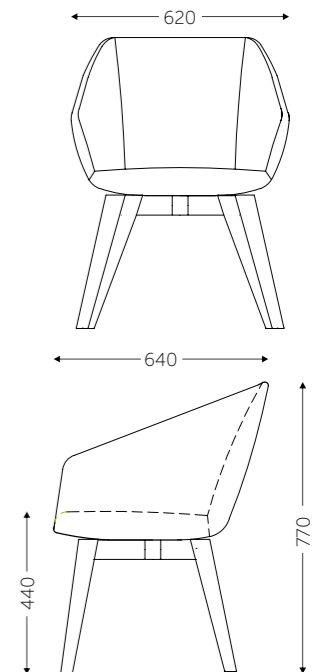

Black Powder Coated



Silver Powder Coated



Alluminium



Solid Wood



Black Powder Coated



Silver Powder Coated



Alluminium



Solid Wood



# NOVA

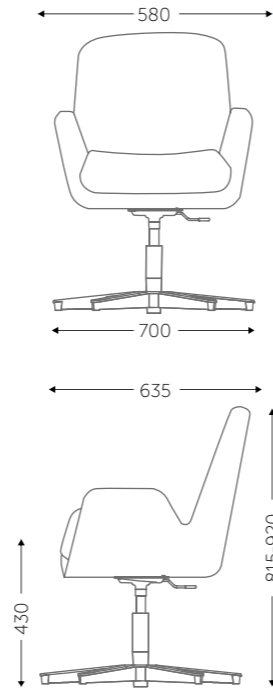

# ELLA

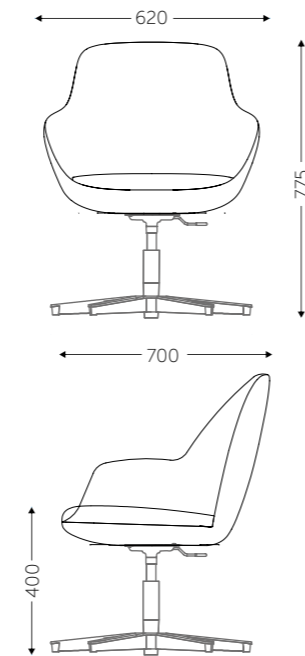

Black Powder Coated



Silver Powder Coated



Alluminium



Solid Wood

# OLIVIA

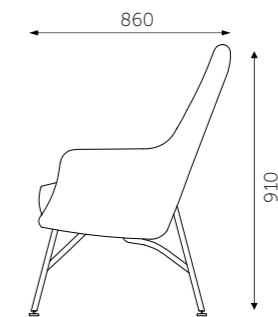
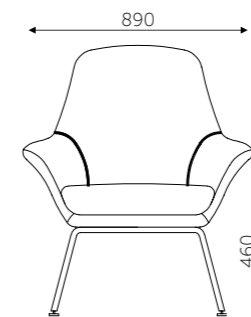

Metal Powder Coated

# FREYA

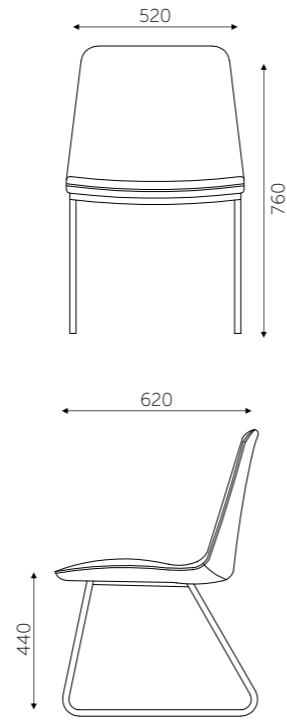

Metal Powder Coated Understructure

# LUCA

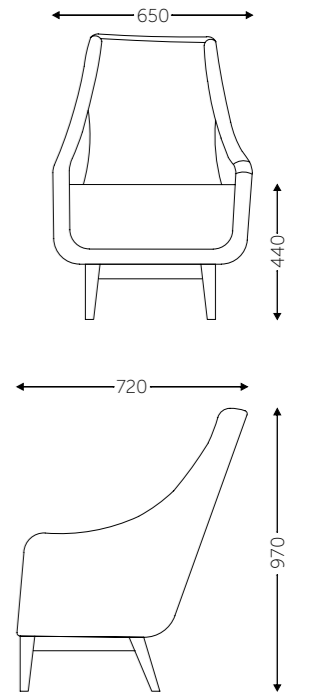

Solid Wood Legs

# ATHENA

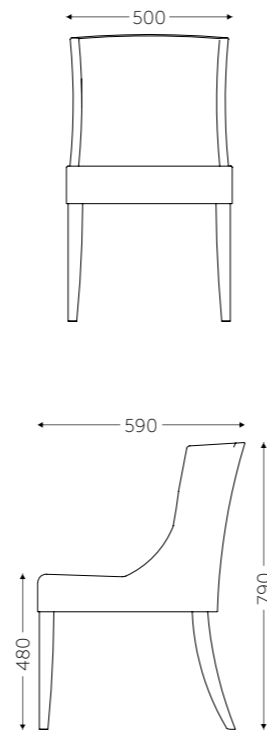

Solid Wood Legs

# LUNA

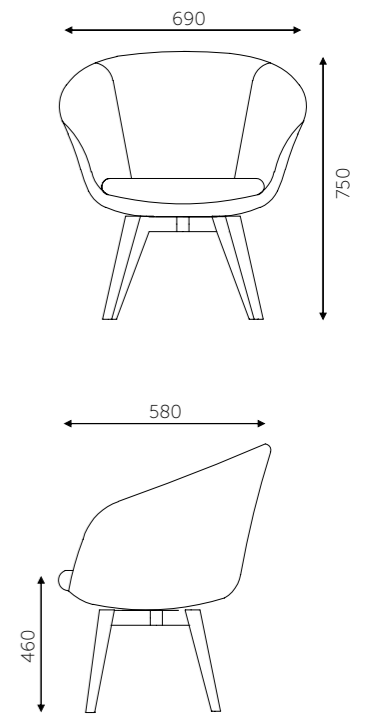

Solid Wood Legs

# WING

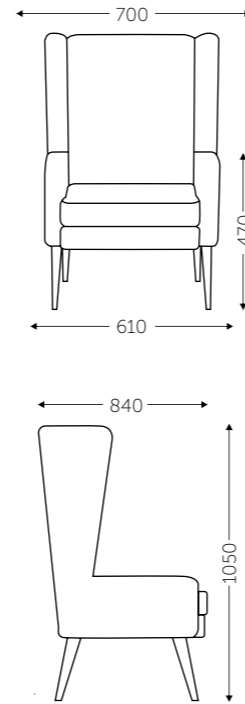

Metal Powder Coated Legs

# AURORA

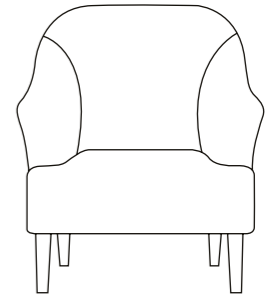

Solid Wood Legs

# CORA

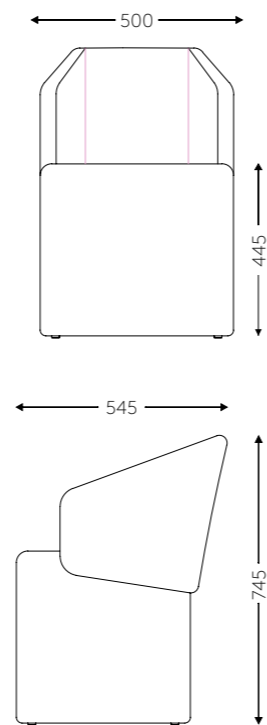

# SIENNA

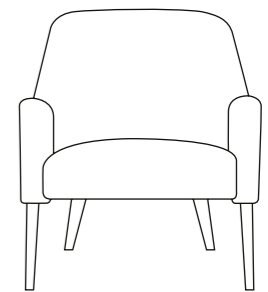

Metal Powder Coated Legs

# INDIGO



Aluminium Base



W 700 x D 500 x H 450-520

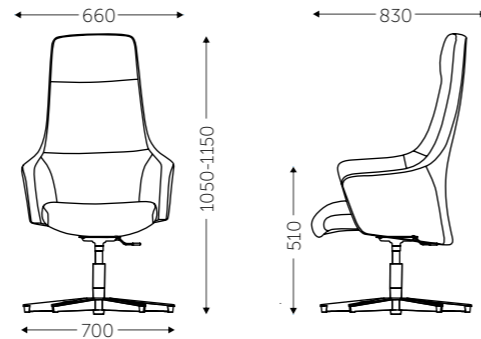

# GLORIA



Aluminium Base



W 700 x D 520 x H 450-550

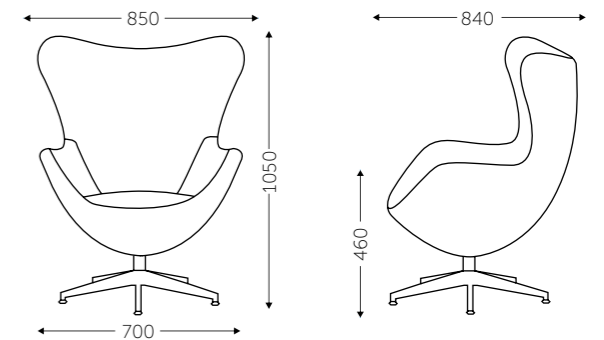



# Highg Chairs & Tables

At Featherlite, we offer a vast array of attractive and functional bar chairs and tables for any environment.

High Stools are an ideal choice for use in a number of different environments where additional height is required such as cafes, restaurants, bars and dining areas. Café, Bar and restaurant stools provide a more relaxed seating solution that can transform any environment.

High Tables are sleek and stylish in design, offering high, casual spaces for catching up and engaging with one another.

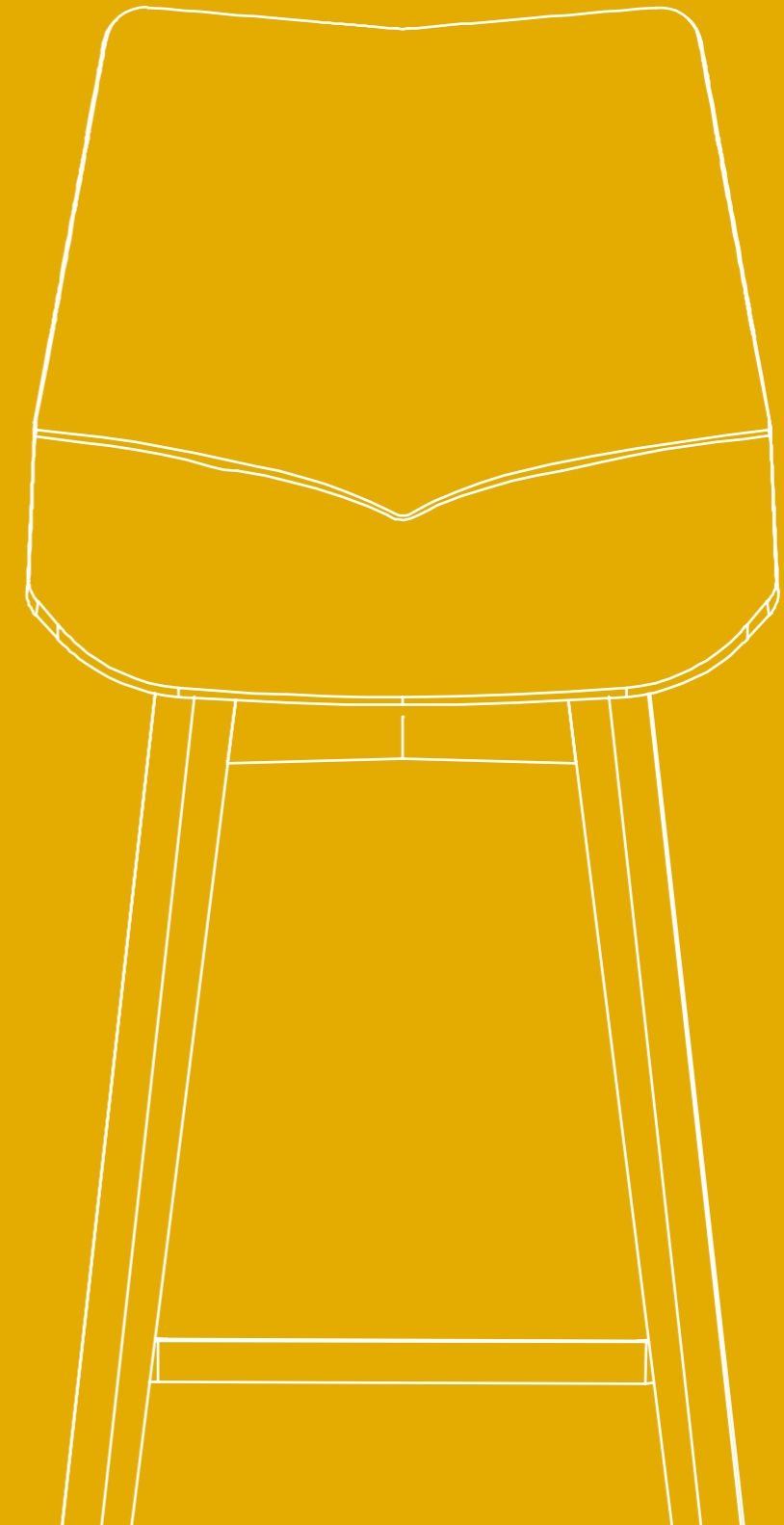

# 04

# HIGH TABLE

WOODEN LEGS



Table Top: PLB (for non cafeteria use)  
 Hydro-Shield (for cafeteria use, Edge finishing will be black)  
 Legs: Solid Wood Legs with Metal Footrest

Chair: Zella Solid Wood Legs

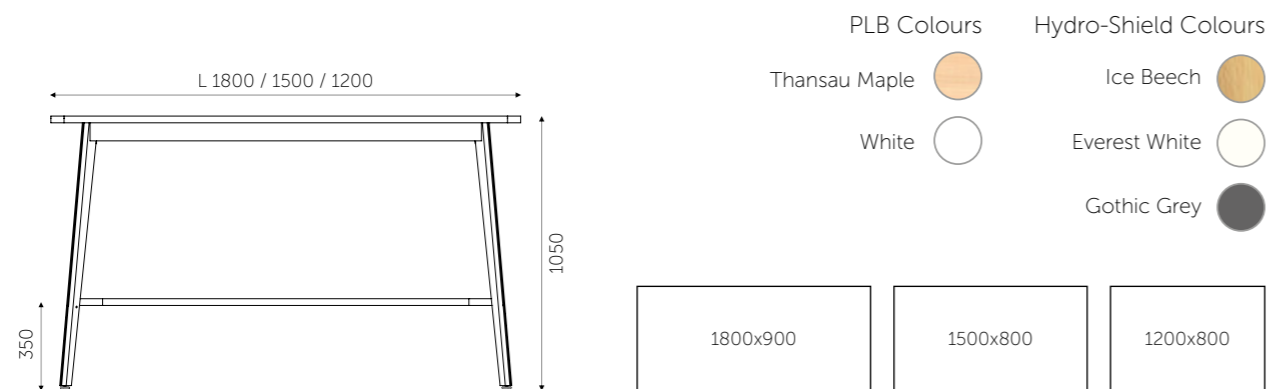

# HIGH TABLE

WOODEN LEGS



Table Top: PLB (for non cafeteria use)  
 Hydro-Shield (for cafeteria use, Edge finishing will be black)  
 Legs: Solid Wood Legs with Metal Footrest

Chair: Leaf Solid Wood Legs

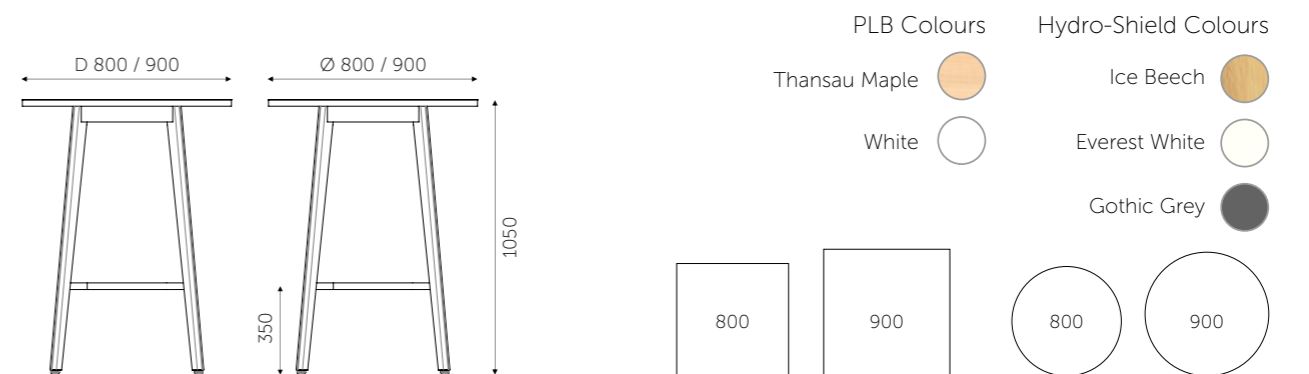

# HIGH TABLE

## SWITCH - METAL ANGULAR LEGS



Table Top: PLB (for non cafeteria use) & Hydro-Shield (for cafeteria use, Edge finishing will be black)  
Legs: Metal

Chair: Leaf Cushion

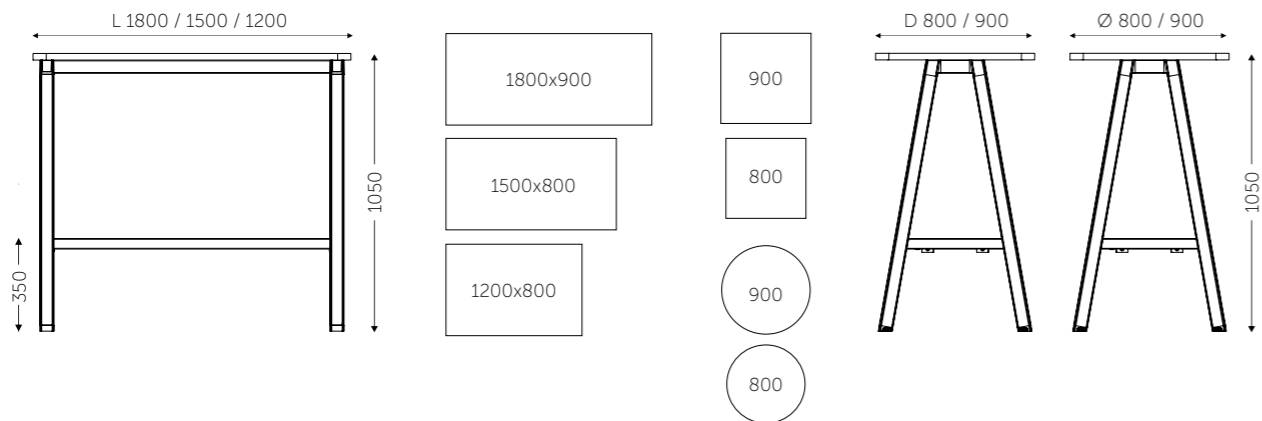

Hydro-Shield Colours

- Ice Beech
- Everest White
- Gothic Grey

PLB Colours

- Thansau Maple
- White

Metal Powder Coating Colours

- Moon Light Grey
- Ivory
- White
- Black
- Dark Grey
- Silver Grey

# HIGH TABLE

## SWITCH - METAL STRAIGHT LEGS



Table Top: PLB (for non cafeteria use) & Hydro-Shield (for cafeteria use, Edge finishing will be black)  
Legs: Metal

Chair: Leaf Cushion

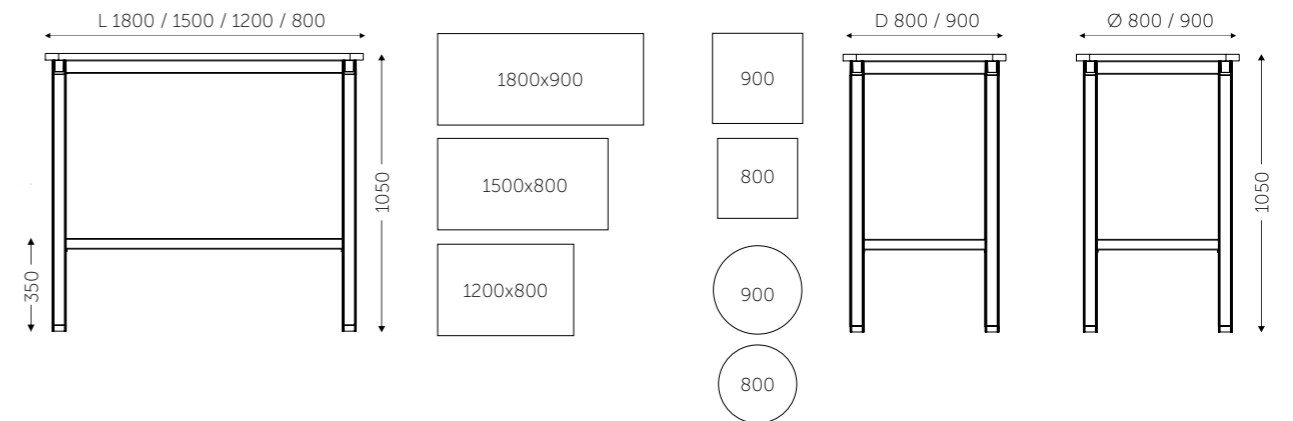

Hydro-Shield Colours

- Ice Beech
- Everest White
- Gothic Grey

PLB Colours

- Thansau Maple
- White

Metal Powder Coating Colours

- Moon Light Grey
- Ivory
- White
- Black
- Dark Grey
- Silver Grey





# HIGH TABLE

PERFORM - METAL LEGS



Table Top: PLB (for non cafeteria use) & Hydro-Shield (for cafeteria use, Edge finishing will be black)  
Legs: Metal

Chair: Loop Cushion

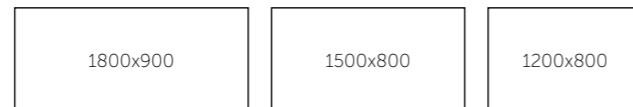
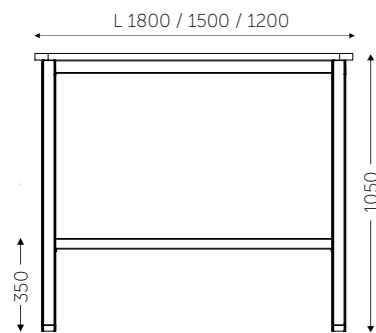

Hydro-Shield Colours

- Ice Beech
- Everest White
- Gothic Grey

PLB Colours

- Thansau Maple
- White

Metal Powder Coating Colours

- Moon Light Grey
- Ivory
- White
- Black
- Dark Grey
- Silver Grey

# HIGH TABLE

PERFORM - METAL LEGS



Table Top: PLB (for non cafeteria use) & Hydro-Shield (for cafeteria use, Edge finishing will be black)  
Legs: Metal

Chair: Loop Cushion

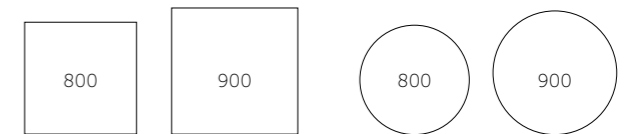
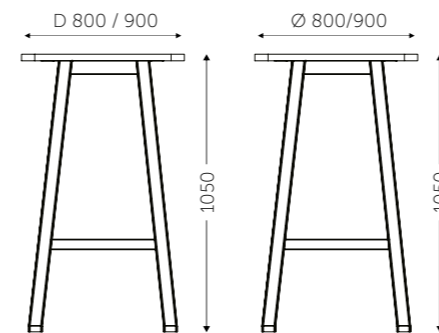

Hydro-Shield Colours

- Ice Beech
- Everest White
- Gothic Grey

PLB Colours

- Thansau Maple
- White

Metal Powder Coating Colours



- Moon Light Grey
- Ivory
- White
- Black
- Dark Grey
- Silver Grey

# ZELLA WOODEN LEGS



Laminated Plywood Seat with Solid Wood Legs

Laminate Colours

-  Hickory Oak
-  Horizontal Ebony
-  White

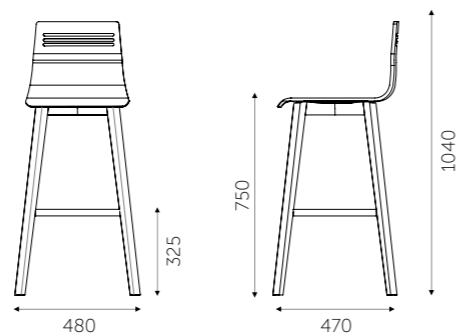

# WOODEN LEGS LEAF



PP Seat Colours

- 
- 
- 
- 
- 
- 

Available with or without Cushion Seat.  
Legs: Solid Wood

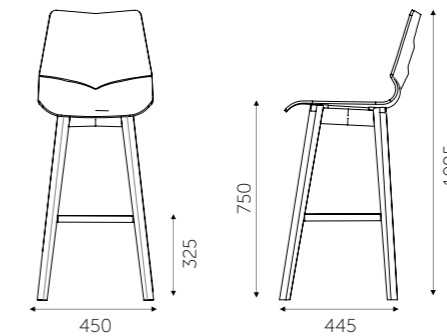

# LEAF METAL LEGS



PP Seat Colours



Frame Colours

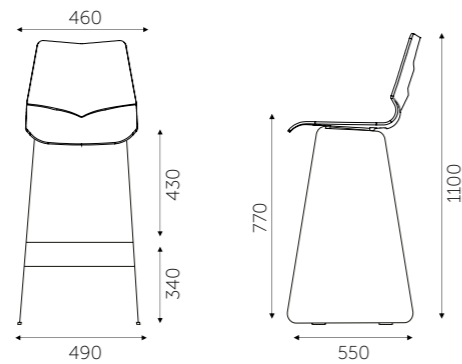

Available with or without Cushion Seat.  
Frame: Metal Powder Coated

# METAL LEGS LOOP



PP Seat Colours



Frame Colours

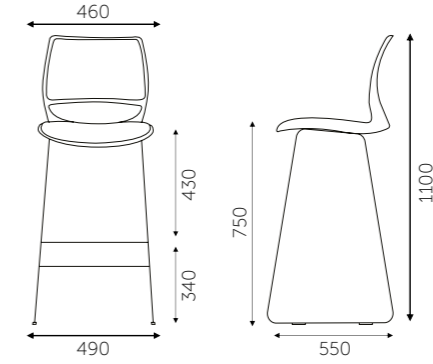

Available with Cushion Seat & Back only.  
Not Available in only Plastic Shell.  
Frame: Metal Powder Coated

# ZELLA

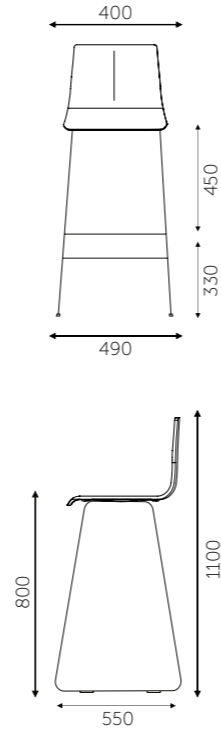

Leatherite / Fabric Seat with Metal Powder Coated Legs

# JAVA

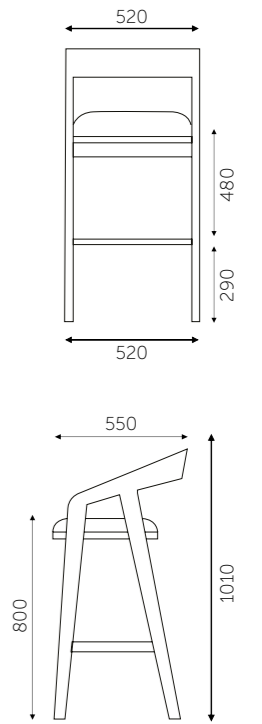

Solid Wood with Cushion Seat

# ARABICA

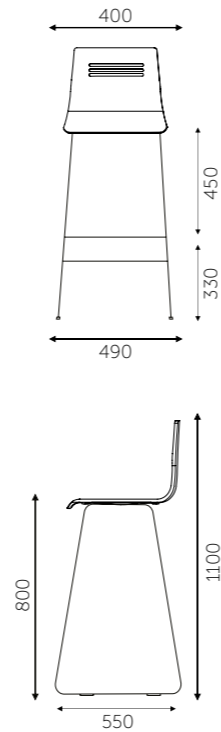

Laminated Plywood Seat with Metal Legs

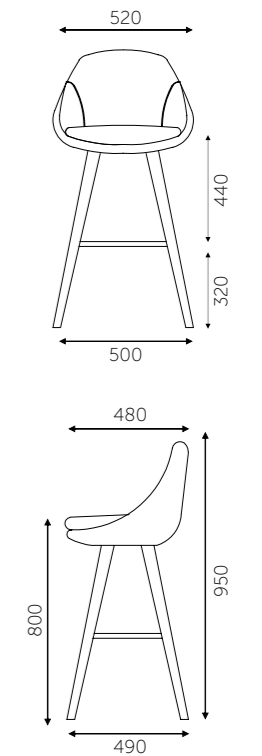

Solid Wood Legs

# ESPRESSO



W 410 x D 410 x H 940

PP Shell with Metal Powder Coated Legs

SEAT COLOURS



POWDER COATING COLOURS



# MOJITO



W 520 x D 450 x H 940

SEAT COLOURS



POWDER COATING COLOURS



PP Shell with Metal Powder Coated Legs

# GIMLET

W 480 x D 535 x H 810



SEAT COLOURS



POWDER COATING COLOURS



# Cafe Chairs & Tables

A quick bite or a long break, our Cafeteria/Casual Seating range complement the hangout needs of all at the academy. Sit down for a long round of chatting, an unofficial meeting, discussion work, or even an academic event planning while lunching with your peers. What's more, there is no fuss, cleaning the mess, thanks to the stain free materials this range is made of.

Some of these chairs are stackable, washable if there were any spills, readily available to arrange and use and available in an assortment of colours.





# 05

# ZELLA WOOD



Laminated Plywood Seat with Solid Wood Legs

### Laminate Colours

-  Hickory Oak
-  Horizontal Ebony
-  White

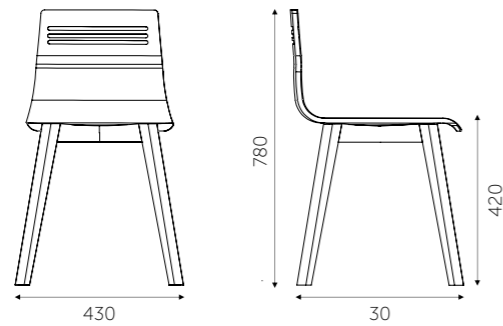

# LEAF WOOD



Available with or without Cushion Seat with Solid Wood Legs

### PP Seat Colours

- 
- 
- 
- 
- 
- 

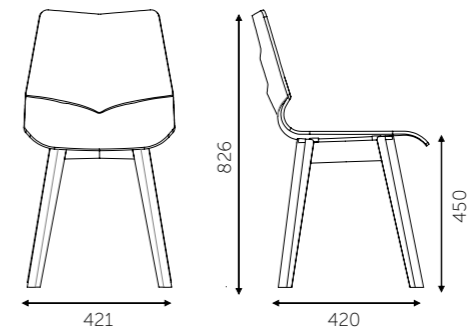



# BASIL



Solid Wood with Cushion Seat

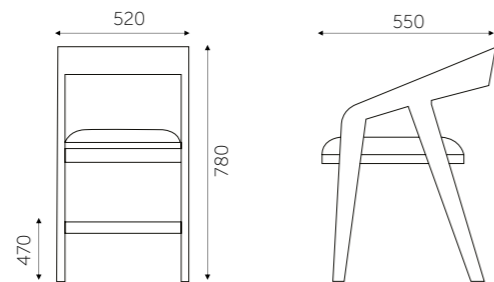

# BOSCO

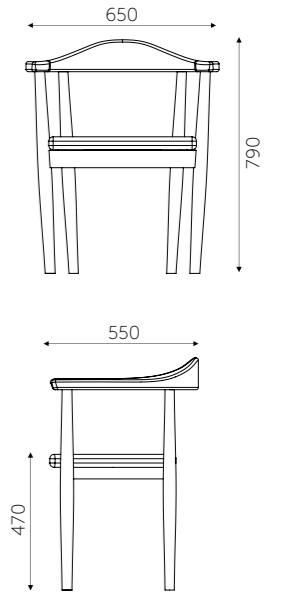

Solid Wood with Cushion Seat

# BURRO

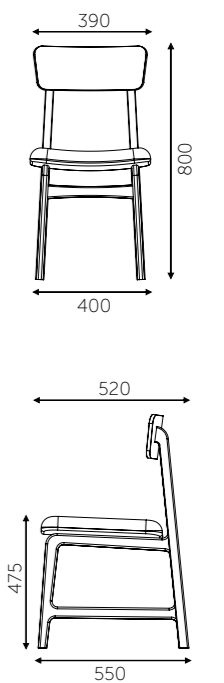

Solid Wood with Cushion Seat

# TANG



RED



BLACK



GREEN



WHITE



ORANGE



GREY



# LEAF SLEDGE BASE



W 530 x D 500 x H 800

Frame Colours

- Moon light Grey

- Black

PP Seat Colours



Available with or without Cushion Seat.  
Frame: Metal Powder Coated

# CUSHION LEAF



W 530 x D 500 x H 800

Frame Colours

- Moon light Grey

- Black

PP Seat Colours



Available with or without Cushion Seat.  
Frame: Metal Powder Coated

# LEAF 4 LEGS



W 515 x D 500 x H 800

Frame Colours

- Moon light Grey

- Black

PP Seat Colours



Available with or without Cushion Seat.  
Frame: Metal Powder Coated

# CUSHION LOOP



W 535 x D 535 x H 840

Frame Colours

- Moon light Grey

- Black

PP Seat Colours



Available with Cushion Seat & Back only.  
Not Available in only Plastic Shell.  
Frame: Metal Powder Coated

# CANDITI



COLOUR VARIATIONS



POWDER COATING COLOURS



# MAIS



COLOUR VARIATIONS



POWDER COATING COLOURS



# FAME



COLOUR VARIATIONS



POWDER COATING COLOURS



# FORNO



SEAT COLOURS



POWDER COATING COLOURS



# GUSTO



W 450 x D 510 x H 780  
PP Shell with Metal Powder Coated Legs  
Available with or without Cushion Seat

COLOUR VARIATIONS



POWDER COATING COLOURS



# AIR



W 590 x D 590 x H 800  
Single Plastic Moulded Chair

COLOUR VARIATIONS



# CRUDO



W 495 x D 520 x H 775  
Single Plastic Moulded Chair

COLOUR VARIATIONS



# NOCI



W 480 x D 540 x H 820  
Single Plastic Moulded Chair

COLOUR VARIATIONS





# Center Tables

06

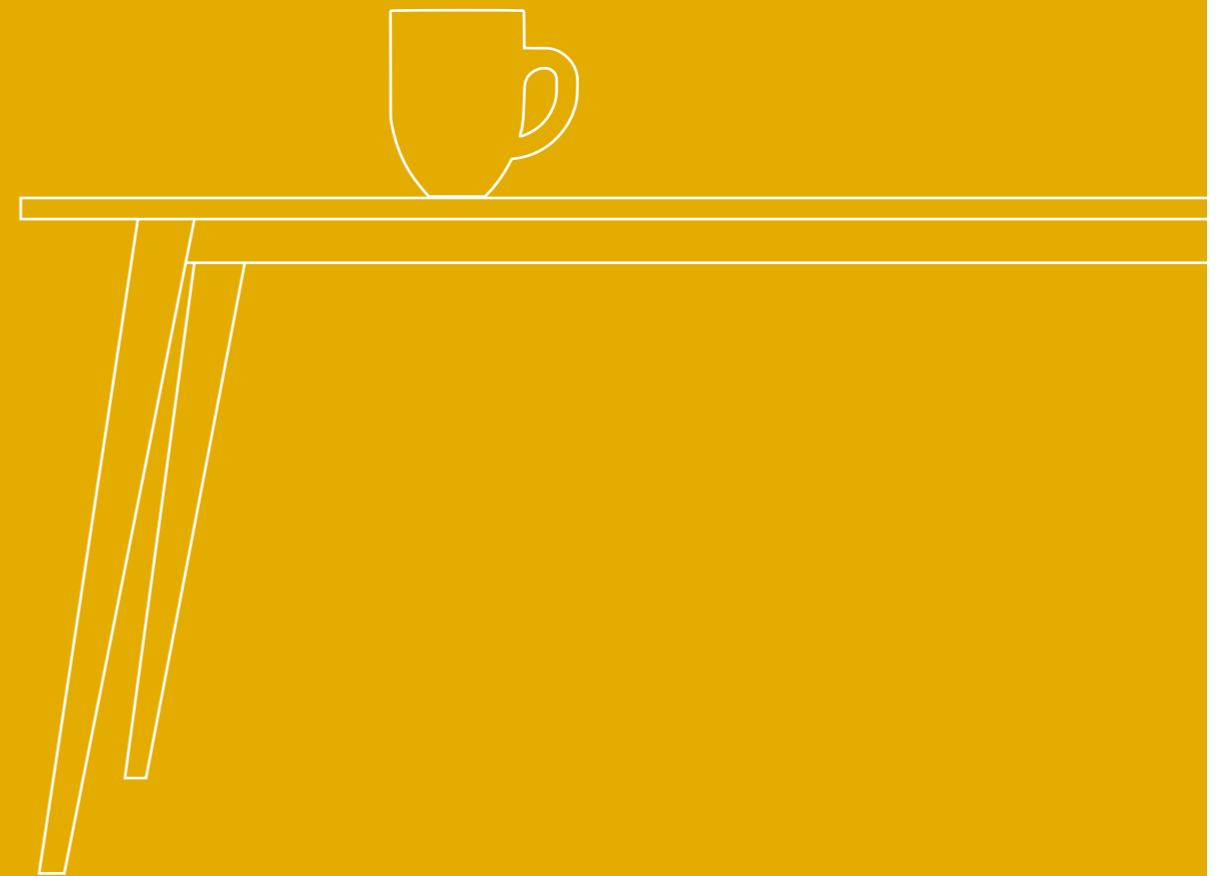

# TABLES

## WOODEN LEGS



Table Top: PLB (for non cafeteria use)  
 Hydro-Shield (for cafeteria use, Edge finishing will be black)  
 Legs: Solid Wood

Chair: Leaf Wooden Legs

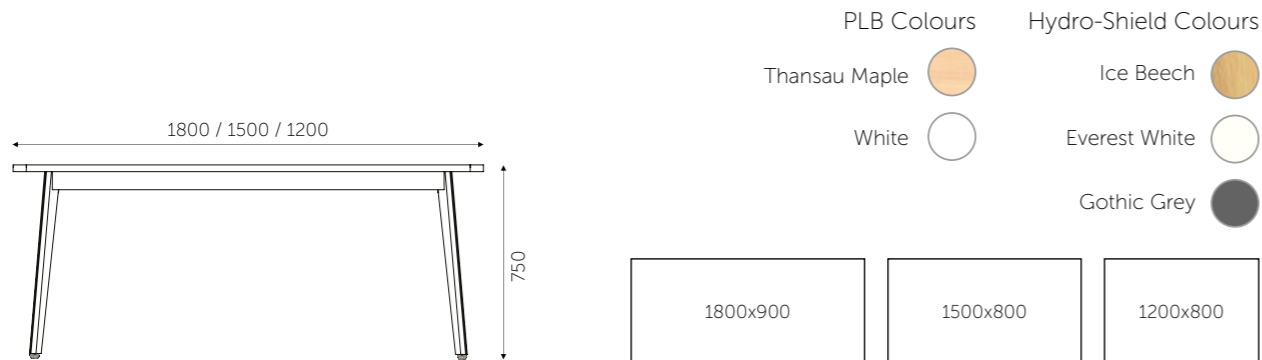

# TABLES

## WOODEN LEGS



Table Top: PLB (for non cafeteria use)  
 Hydro-Shield (for cafeteria use, Edge finishing will be black)  
 Legs: Solid Wood

Chair: Zella Wooden Legs

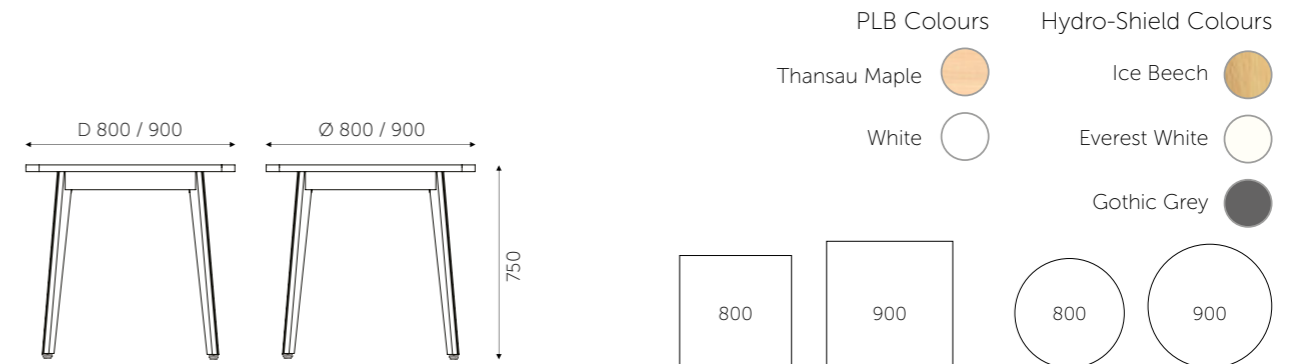



# TABLES

## SWITCH ANGULAR - METAL LEGS



Table Top: PLB (for non cafeteria use)  
Hydro-Shield (for cafeteria use, Edge finishing will be black)  
Legs: Metal

Chair: Loop Cushion

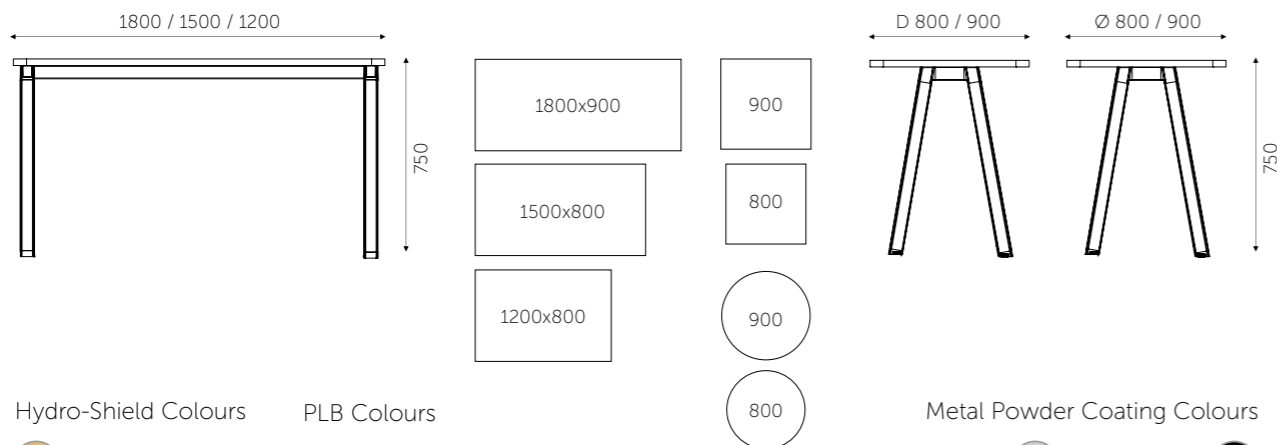

Hydro-Shield Colours

- Ice Beech
- Everest White
- Gothic Grey

PLB Colours

- Thansau Maple
- White

Metal Powder Coating Colours

- Moon Light Grey
- Ivory
- White
- Black
- Dark Grey
- Silver Grey

# TABLES

## SWITCH STRAIGHT - METAL LEGS



Table Top: PLB (for non cafeteria use)  
Hydro-Shield (for cafeteria use, Edge finishing will be black)  
Legs: Metal

Chair: Leaf Cushion

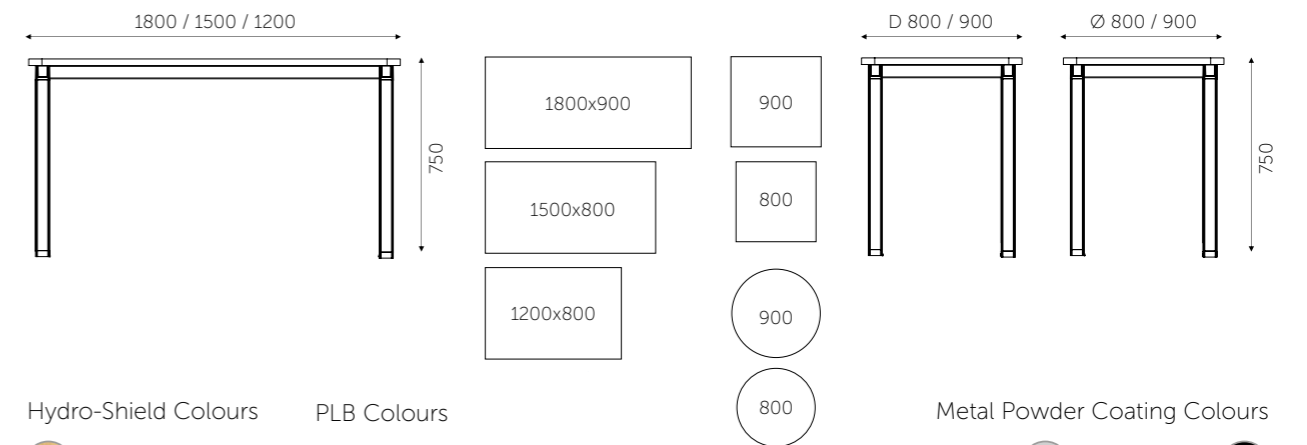

Hydro-Shield Colours

- Ice Beech
- Everest White
- Gothic Grey

PLB Colours

- Thansau Maple
- White

Metal Powder Coating Colours

- Moon Light Grey
- Ivory
- White
- Black
- Dark Grey
- Silver Grey

# TABLES

## PERFORM - METAL LEGS



Table Top: PLB (for non cafeteria use)  
Hydro-Shield (for cafeteria use, Edge finishing will be black)  
Legs: Metal

Chair: Loop Cushion

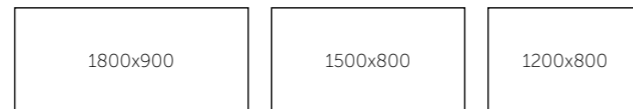
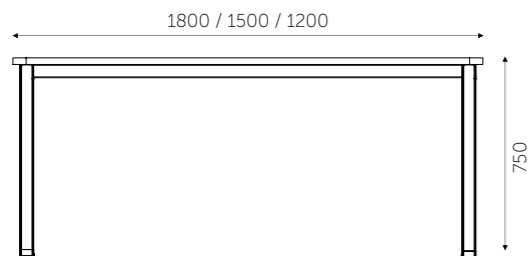

Hydro-Shield Colours

- Ice Beech
- Everest White
- Gothic Grey

PLB Colours

- Thansau Maple
- White

Metal Powder Coating Colours

- Moon Light Grey
- Ivory
- White
- Black
- Dark Grey
- Silver Grey

# TABLES

## PERFORM - METAL LEGS



Table Top: PLB (for non cafeteria use)  
Hydro-Shield (for cafeteria use, Edge finishing will be black)  
Legs: Metal

Chair: Leaf Cushion

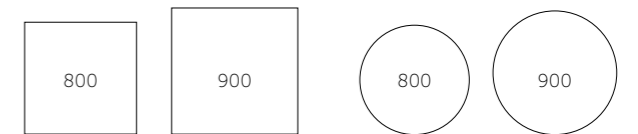
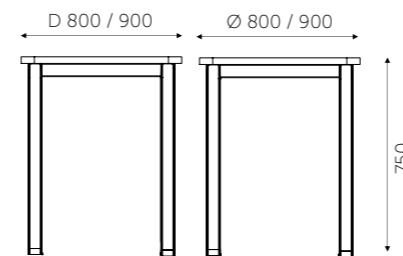

Hydro-Shield Colours

- Ice Beech
- Everest White
- Gothic Grey

PLB Colours

- Thansau Maple
- White

Metal Powder Coating Colours

- Moon Light Grey
- Ivory
- White
- Black
- Dark Grey
- Silver Grey

# TABLES

## SYNERGY - METAL LEGS



Table Top: PLB (for non cafeteria use)  
Hydro-Shield (for cafeteria use, Edge finishing will be black)  
Legs: Metal

Chair: Loop Cushion

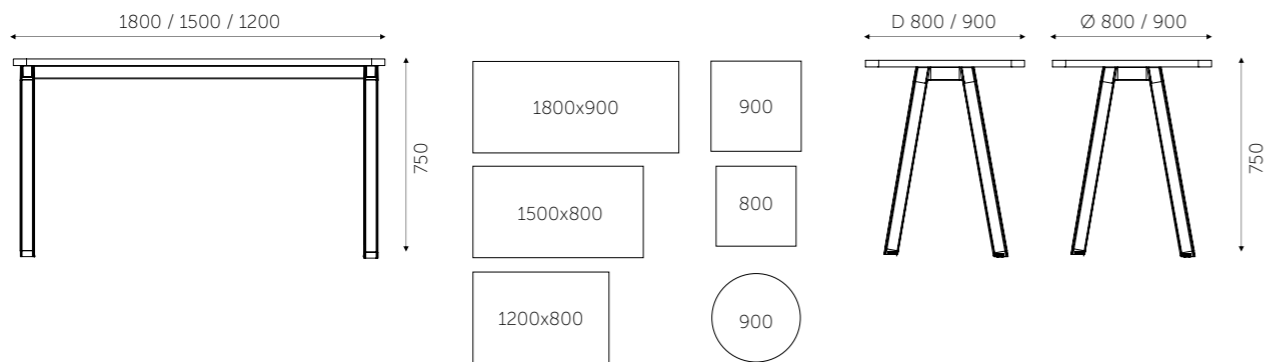

Hydro-Shield Colours

- Ice Beech
- Everest White
- Gothic Grey

PLB Colours

- Thansau Maple
- White

Metal Powder Coating Colours

- Moon Light Grey
- Ivory
- White
- Black
- Dark Grey
- Silver Grey

# LOOP

## TABLE & BENCH



Table & Bench Top: Rubber Wood | Legs: Metal Powder Coated

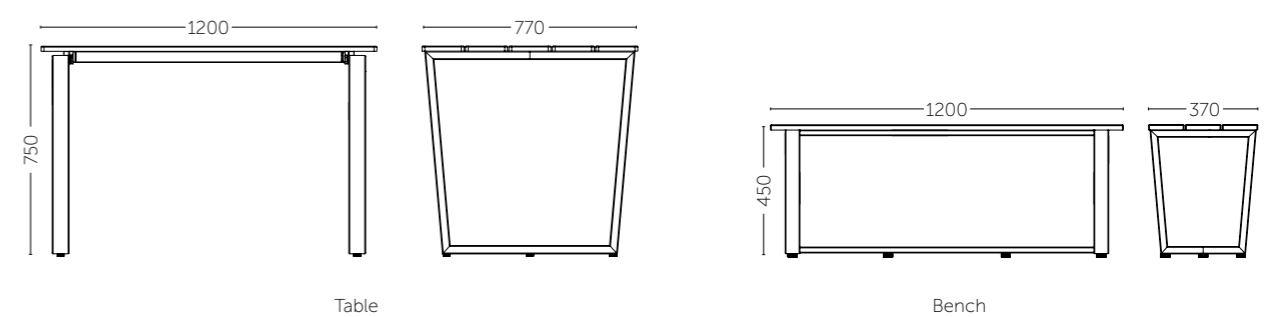

Rubber Wood Colours

- Walnut
- Natural Clear

Powder Coating Colours

- Black
- Dark Grey
- Moon Light Grey

# CENTER TABLES

## SOLID WOOD LEGS

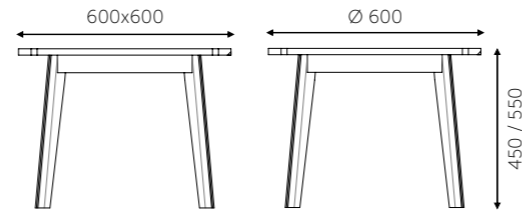
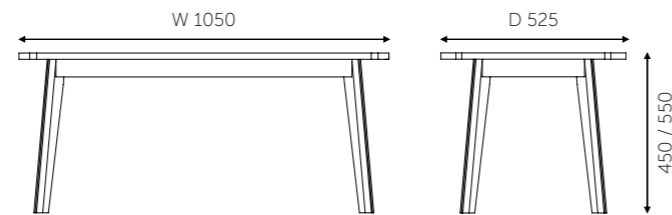

Table Top: PLB (for non cafeteria use ) & Hydro-Shield (for cafeteria use, Edge finishing will be black) | Legs: Solid Wood Legs



- PLB Colours
- Thansau Maple
  - White

- Hydro-Shield Colours
- Ice Beech
  - Everest White
  - Gothic Grey



# CENTER TABLES

## METAL LEGS



RECTANGLE SHAPE  
L 1050 x D 600 x H 450 / 550



OVAL SHAPE  
L 1050 x D 600 x H 450 / 550

Table Top: PLB (for non cafeteria use ) & Hydro-Shield (for cafeteria use, Edge finishing will be black) | Legs: Metal Powder Coated



ROUND SHAPE  
Ø 600 x H 450 / 550



SQUARE SHAPE  
L 600 x D 600 x H 450 / 550

- PLB Colours
- Thansau Maple
  - White

- Hydro-Shield Colours
- Ice Beech
  - Everest White
  - Gothic Grey

- Powder Coating Colours
- Black
  - Dark Grey
  - Moon Light Grey



# MAJESTIC

METAL LEGS

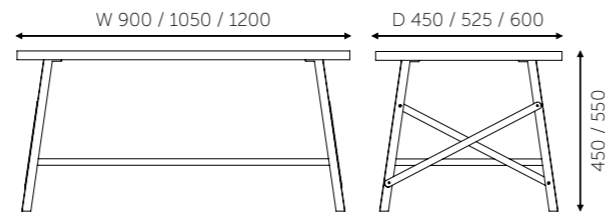
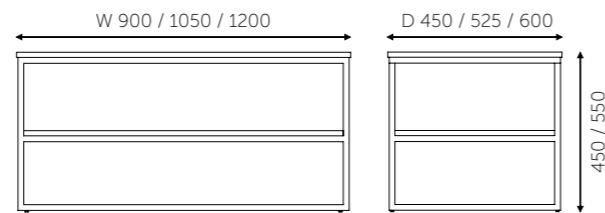

Table Top: PLB (for non cafeteria use), Stained Rubber Wood & Hydro-Shield (for cafeteria use, Edge finishing will be black)

# REGAL

METAL LEGS



PLB Colours

- Thansau Maple
- White

Hydro-Shield Colours

- Ice Beech
- Everest White
- Gothic Grey

Stained Rubber Wood Colours

- Walnut
- Natural Clear

Powder Coating Colours

- Black
- Dark Grey
- Moon Light Grey

# TRANQUIL

METAL LEGS

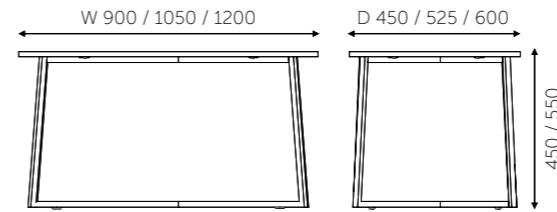
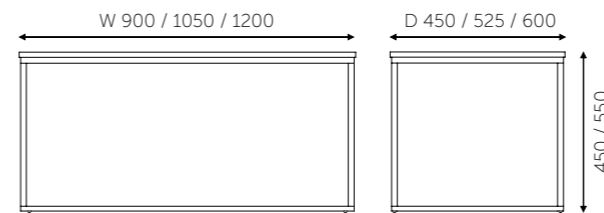

Table Top: PLB (for non cafeteria use), Stained Rubber Wood & Hydro-Shield (for cafeteria use, Edge finishing will be black)

# HARMONY

METAL LEGS



PLB Colours

- Thansau Maple
- White

Hydro-Shield Colours

- Ice Beech
- Everest White
- Gothic Grey

Stained Rubber Wood Colours

- Walnut
- Natural Clear

Powder Coating Colours

- Black
- Dark Grey
- Moon Light Grey

# ELEGANCE

## METAL LEGS

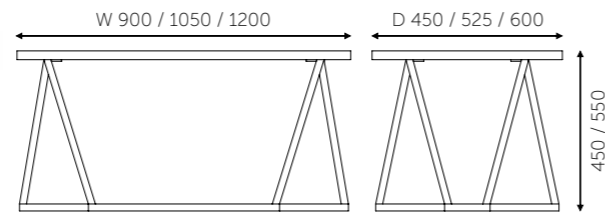
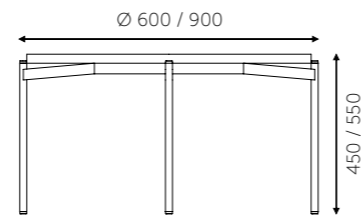

Table Top: PLB (for non cafeteria use), Stained Rubber Wood & Hydro-Shield (for cafeteria use, Edge finishing will be black)

# GLAMOUR

## METAL LEGS



PLB Colours

- Thansau Maple
- White

Hydro-Shield Colours

- Ice Beech
- Everest White
- Gothic Grey

Stained Rubber Wood Colours

- Walnut
- Natural Clear

Powder Coating Colours

- Black
- Dark Grey
- Moon Light Grey

# GRACE

## METAL LEGS

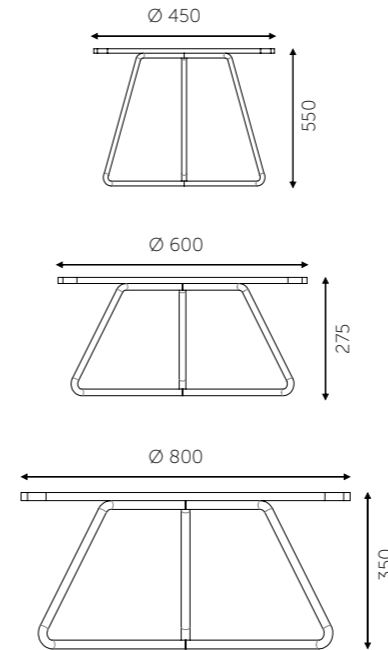
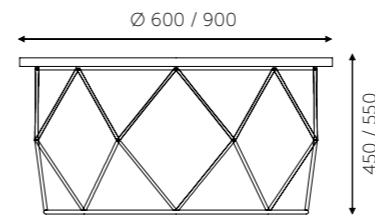

Table Top: PLB (for non cafeteria use), Stained Rubber Wood & Hydro-Shield (for cafeteria use, Edge finishing will be black)

# COSMO

## METAL LEGS



PLB Colours

- Thansau Maple
- White

Hydro-Shield Colours

- Ice Beech
- Everest White
- Gothic Grey

Stained Rubber Wood Colours

- Walnut
- Natural Clear

Powder Coating Colours

- Black
- Dark Grey
- Moon Light Grey

# FLOAT

HIGH TABLE & BENCH



Table Top: PLB (for non cafeteria use) & Hydro-Shield (for cafeteria use, Edge finishing will be black)  
 Bench Top: Moulded Plywood with or without Cushion Seat | Legs: Metal Powder Coated

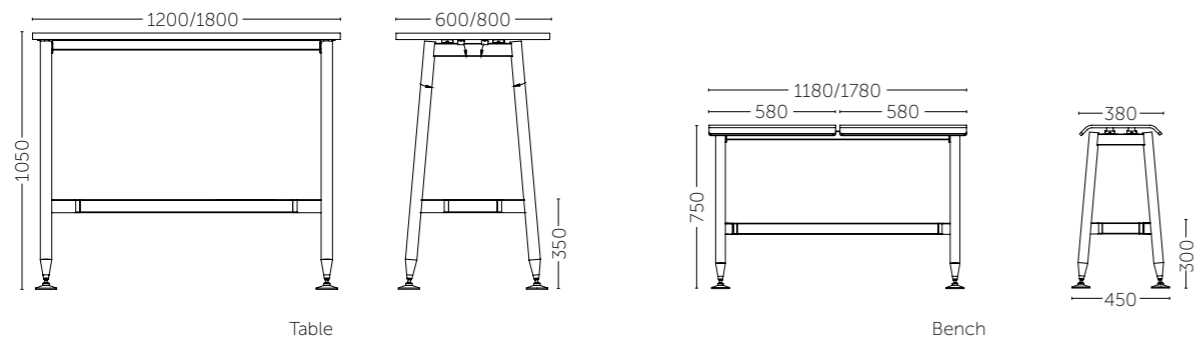

# SWITCH

HIGH TABLE & BENCH



Table Top: PLB (for non cafeteria use) & Hydro-Shield (for cafeteria use, Edge finishing will be black)  
 Bench Top: Moulded Plywood with or without Cushion Seat | Legs: Metal Powder Coated

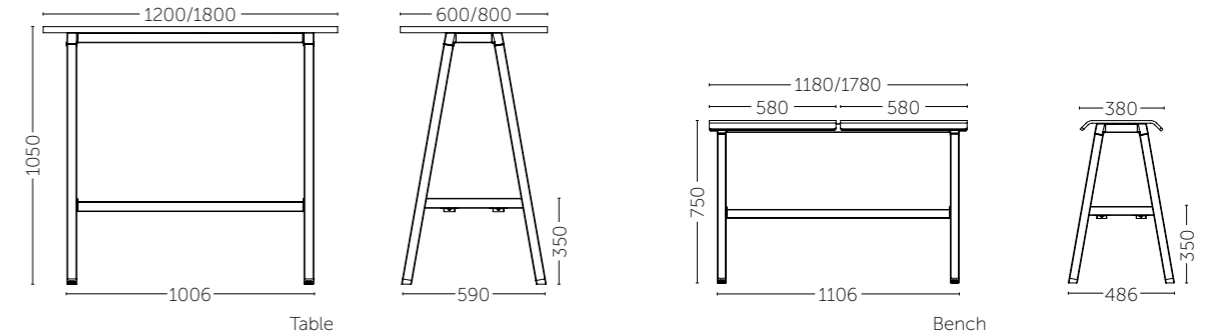



# IRIS

HEIGHT ADJUSTABLE TABLE

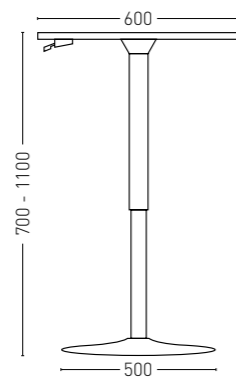

# LYRA

Table Top: ISO & Hydro-Shield (for cafeteria use), Hydro-Shield Edge finishing will be black | Legs: Metal Powder Coated



L 1200 x D 800 x H 750  
L 1800 x D 900 x H 750



Ø 914 x H 750



ISO Table Top Colours

- Thansau Maple
- White

Hydro-Shield Colours

- Ice Beech
- Everest White
- Gothic Grey

# ATLAS

Table Top: ISO & Hydro-Shield (for cafeteria use), Hydro-Shield Edge finishing will be black) | Legs: SS



L 1200 x D 800 x H 750  
L 1800 x D 900 x H 750



L 800 x D 800 x H 750



Ø 914 x H 750



### ISO Table Top Colours

- Thansau Maple
- White

### Hydro-Shield Colours

- Ice Beech
- Everest White
- Gothic Grey

# LUCAS

Table Top: ISO & Hydro-Shield (for cafeteria use), Hydro-Shield Edge finishing will be black) | Legs: Metal Powder Coated



L 1200 x D 800 x H 750  
L 1800 x D 900 x H 750



L 800 x D 800 x H 750



Ø 914 x H 750

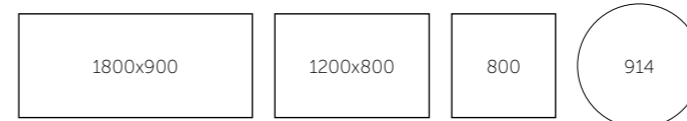

### ISO Table Top Colours

- Thansau Maple
- White

### Hydro-Shield Colours

- Ice Beech
- Everest White
- Gothic Grey

### Metal Powder Coating Colours

- Moon Light Grey
- Ivory
- White
- Black
- Dark Grey
- Silver Grey

# CAFE CHROME

Table Top: ISO & Hydro-Shield (for cafeteria use), Hydro-Shield Edge finishing will be black) | Legs: Chrome



L 1200 x D 800 x H 750  
L 1800 x D 900 x H 750



L 800 x D 800 x H 750



Ø 914 x H 750

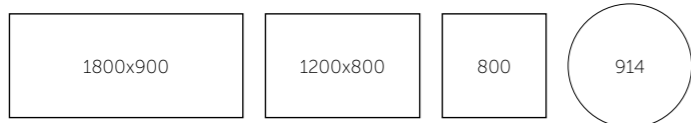

ISO Table Top Colours

- Thansau Maple
- White

Hydro-Shield Colours

- Ice Beech
- Everest White
- Gothic Grey

# CAFE FOLD

Table Top: ISO & Hydro-Shield (for cafeteria use), Hydro-Shield Edge finishing will be black) | Legs: SS



L 1200 x D 800 x H 750  
L 1800 x D 900 x H 750



L 800 x D 800 x H 750      Ø 914 x H 750

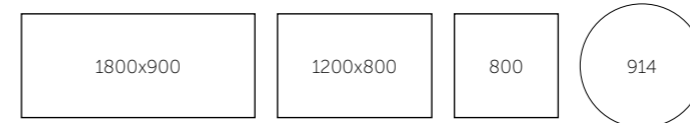

ISO Table Top Colours

- Thansau Maple
- White

Hydro-Shield Colours

- Ice Beech
- Everest White
- Gothic Grey



# Training

When it comes to designing a training room, furniture plays a crucial role in creating an environment that is conducive to learning and productivity.

Featherlites range of training room furniture is designed to be durable, and flexible enough to accommodate different training styles and activities.

# 07



# NOMAD



TV Space + Marker Board + Storage  
 Marker Board: L 1500 / 1200 x H 900 | Storage: L 1500 / 1200 x D 300 x H 300  
 L 1560 x D 560 x H 1800mm (for 65" T.V) | L 1260 x D 560 x H 1800mm (for 50" T.V)



TV Space + Marker Board  
 L 1560 x D 560 x H 1800mm (for 65" T.V)  
 L 1260 x D 560 x H 1800mm (for 50" T.V)  
 Marker Board: L 1200 / 1500 x H 900  
 Wooden Shelf: L 900 x D 150



TV Space + Full Marker Board  
 L 1560 x D 560 x H 1800mm (for 65" T.V)  
 L 1260 x D 560 x H 1800mm (for 50" T.V)  
 Marker Board: L 1200 / 1500 x H 1650  
 Wooden Shelf: L 900 x D 150



2 Sided Full Marker Board  
 L 1560 x D 560 x H 1800mm  
 L 1260 x D 560 x H 1800mm  
 Marker Board: L 1200 / 1500 x H 1650  
 Wooden Shelf: L 900 x D 150



Double Side Marker Board with Storage  
 L 1560 x D 560 x H 1800mm  
 L 1260 x D 560 x H 1800mm  
 Marker Board: L 1500 / 1200 x H 900  
 Storage: L 1500 / 1200 x D 300 x H 300



Marker Board + Soft Board with Shelf and Planter  
 L 1560 x D 560 x H 1800mm  
 L 1260 x D 560 x H 1800mm  
 Marker Board: L 1500 / 1200 x H 900  
 Wodden Shelf: L 1500 / 1200 x D 300 | Planter: L 1500 / 1200 x D 300 x H 200



Movable Shelving Unit  
 L 1560 x D 560 x H 1800mm  
 L 1260 x D 560 x H 1800mm  
 Wooden Shelf: L 1500 / 1200 x D 300



Movable Shelving Unit + Planters  
 L 1560 x D 560 x H 1800mm  
 L 1260 x D 560 x H 1800mm  
 Wooden Shelf: L 1500 / 1200 x D 300  
 Planters: L 1500 / 1200 x D 300 x H 200

# FOLDING TABLE

TRAINING & CONFERENCE



TYPE A



TYPE B

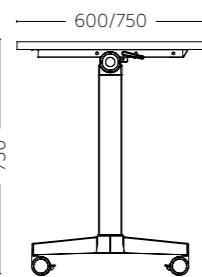
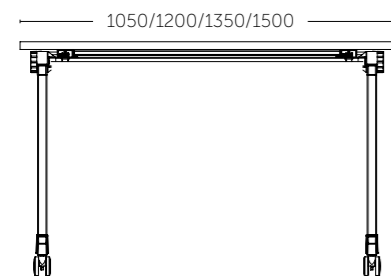

750

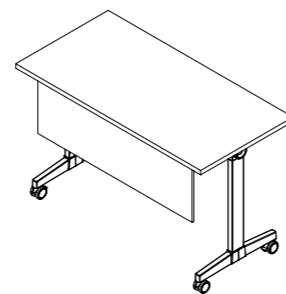

with modesty panel

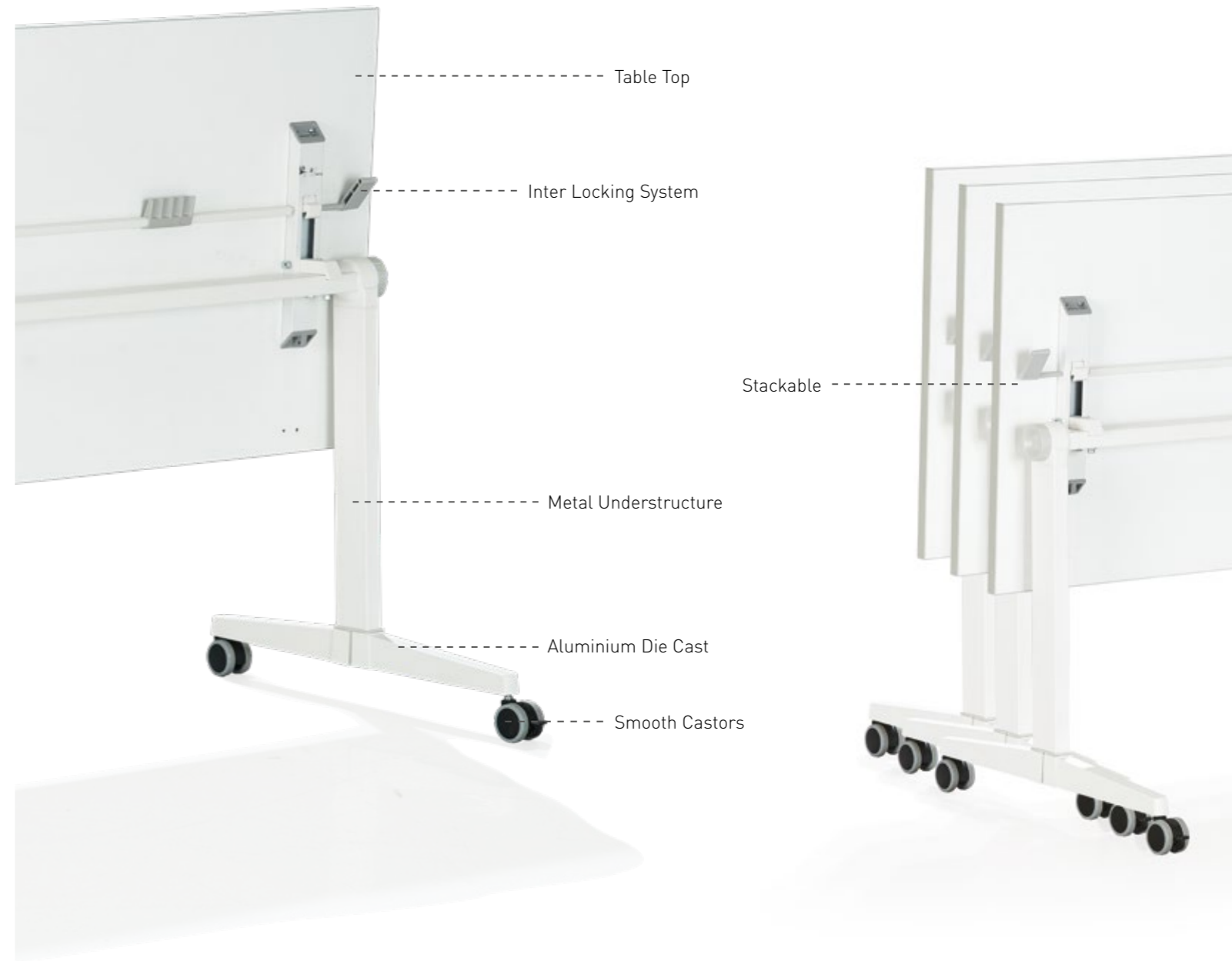

### Configurations

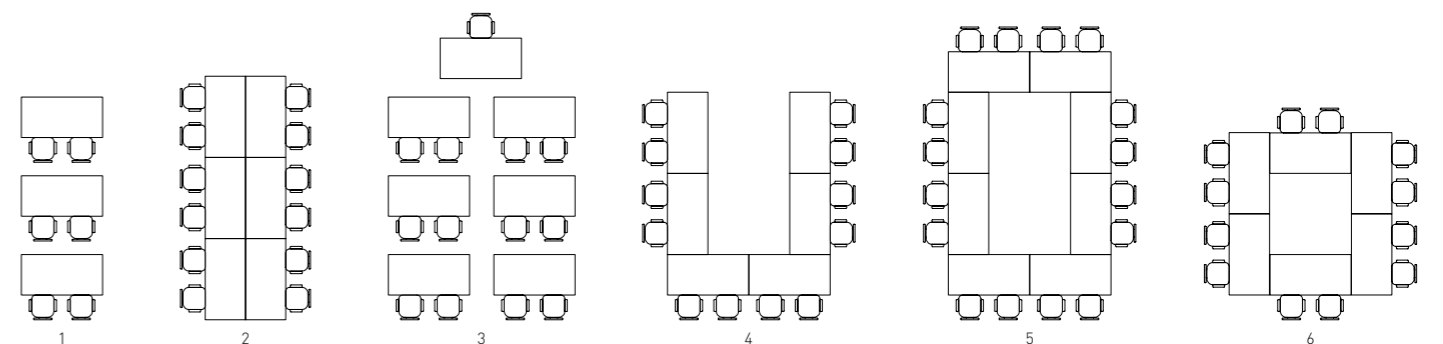





# Benches

Whether it be through smooth curves or sharp straight lines, our range of contemporary benches add significant character to your workspace. Our benches are movable and reconfigurable to be able to have quick, impromptu meetings anytime, anywhere. Lightweight, yet sturdy in design, Featherlite benches encourage easy and hassle free collaboration. With a vast range of fabric options, these benches add a flair of colour and liveliness to your space.

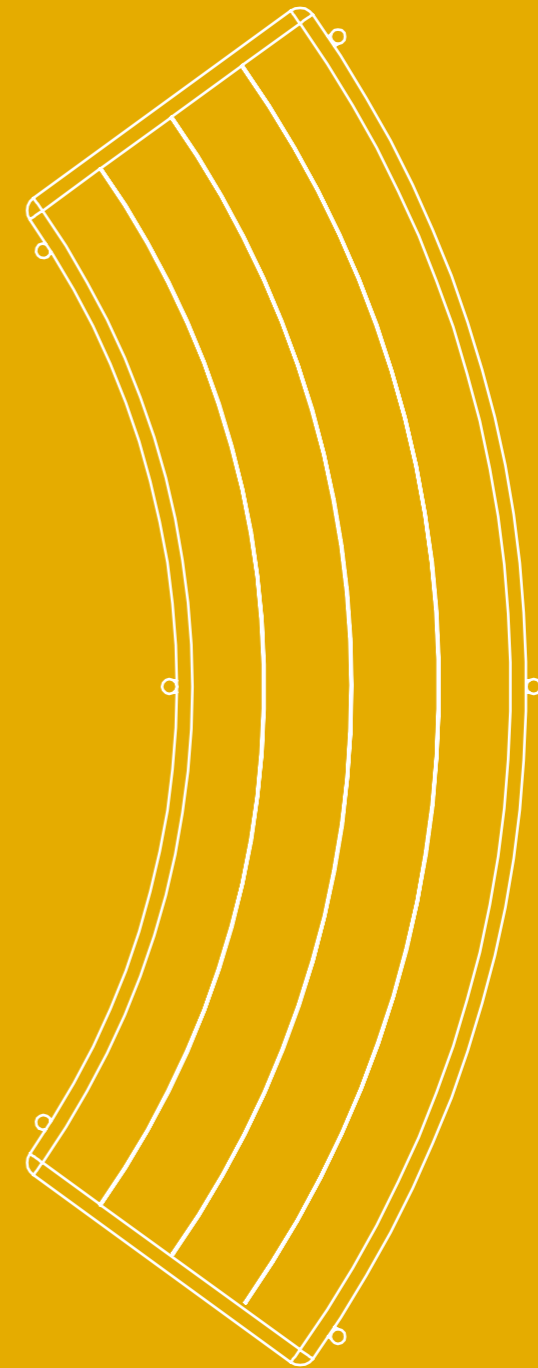

# 08

# VIVID



CURVED BENCH  
L 1750 / 915 x D 450 x H 450



RECTANGLE BENCH  
L 1300 x D 450 x H 450



SQUARE BENCH  
L 450 x D 450 x H 450



ROUND BENCH  
Dia 450 x H 450

# VIVID



# METAL BENCH



Fluorescent Green



Pink



Red

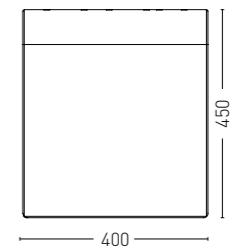
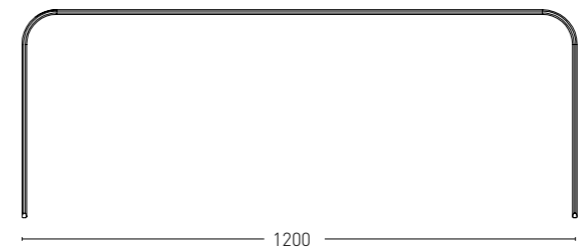

# Pouffes

A simple yet highly impactful add on to any workspace, Pouffes allow you to increase the number of seats available in any configuration. Light designs which are easy to move make the pouffe a convenient option when looking for additional seating in any space. Unique shapes and colours of the pouffe give the office space a youthful, and energetic appearance.

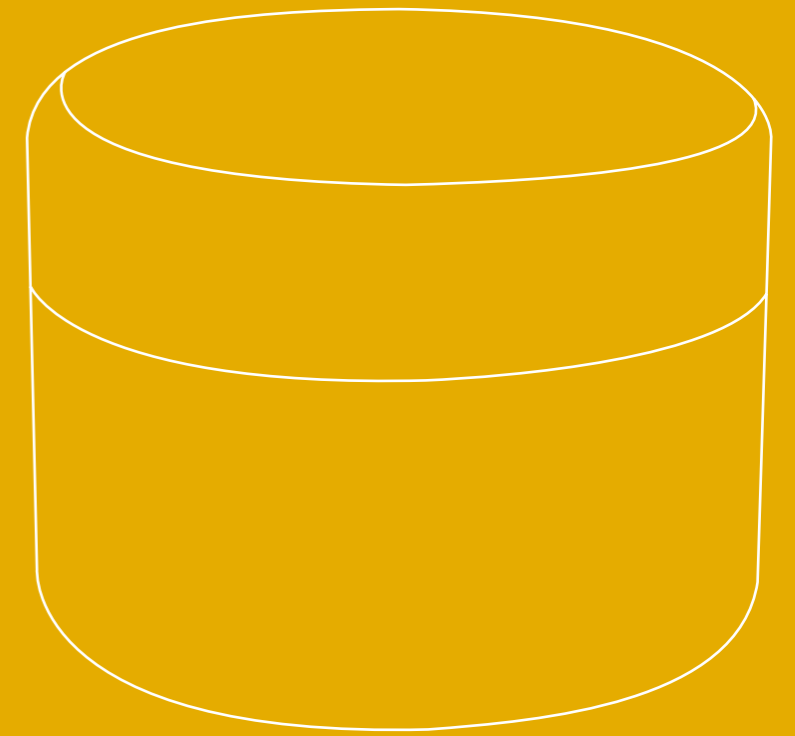

09

# POUFFE



Circa  
W 600 x D 600 x H 450 mm



Cylvia  
W 390 x D 390 x H 450 mm



Duo  
W 1000 x D 500 x H 395 mm



Boomerang  
with & without Castors W 650 x D 750 x H 725



Conical  
Dia 490 / 390 x H 450 mm



Quart de  
W 620 x D 450 x H 385 mm



Penta  
W 590 x D 570 x H 385 mm



Qube  
W 410 x D 390 x H 385 mm



Saddle  
W 800 x D 400 x H 500

# Laptop Tables

Sturdy, yet mobile, our range of Laptop Tables allow users to work or take calls in any space. These sleek designs are easily relocated to where they are required, and fit easily as a necessary accessory to any seating space.

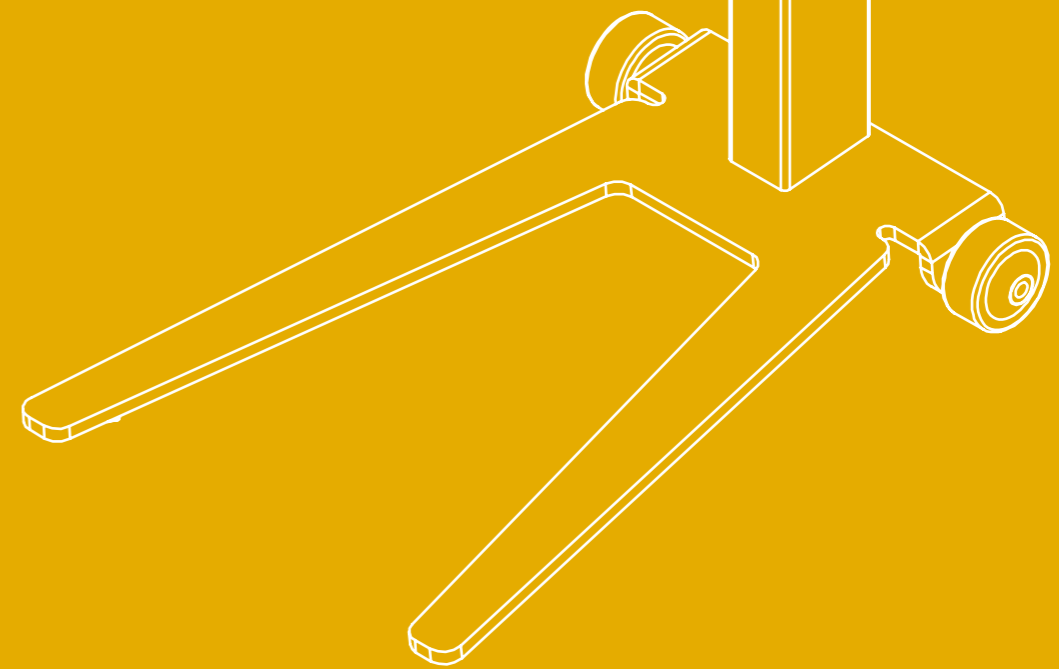

# 10

# SPIKY



## TECHNICAL DETAILS

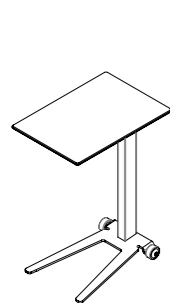

L 400 x D 500 x H 675 mm

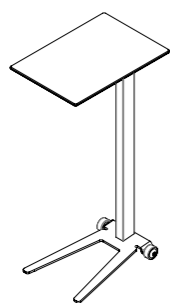

L 450 x D 500 x H 1000 mm

# BRISK

Table Top: ISO / Hydro-Shield (for cafeteria use, Edge finishing will be black)



## TECHNICAL DETAILS



Rectangle  
L 550 x D 450 x H 675



Square  
L 450 x D 450 x H 675

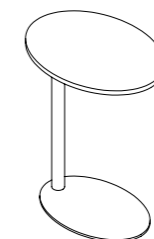

Oval  
L 550 x D 400 x H 675

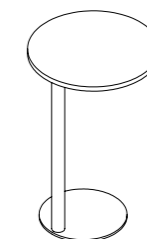

Round  
Dia 450 x H 675

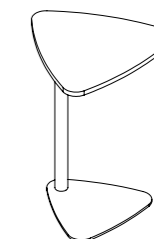

Triangle  
L 465 x D 495 x H 675

### ISO Table Top Colours

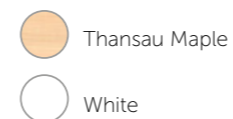

### Hydro-Shield Colours



### Metal Powder Coating Colours

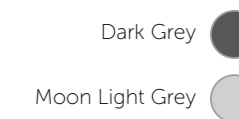



# Tetris

Traditional dividers and PVC screens are expensive, not good for the environment and an eyesore.

We're here to change that, our line of dividers harnesses the beauty of nature to enhance your workspace, instead of detracting from it.

Our Tetris range is a fantastic choice for those looking to partition their office and increase their storage capacity. The modular shelves that make up the grid can be provided with a range of interesting attachment options in several different variations.

They can also be paired with a range of planting options and the frame of the grid itself is available in grey, white and black.

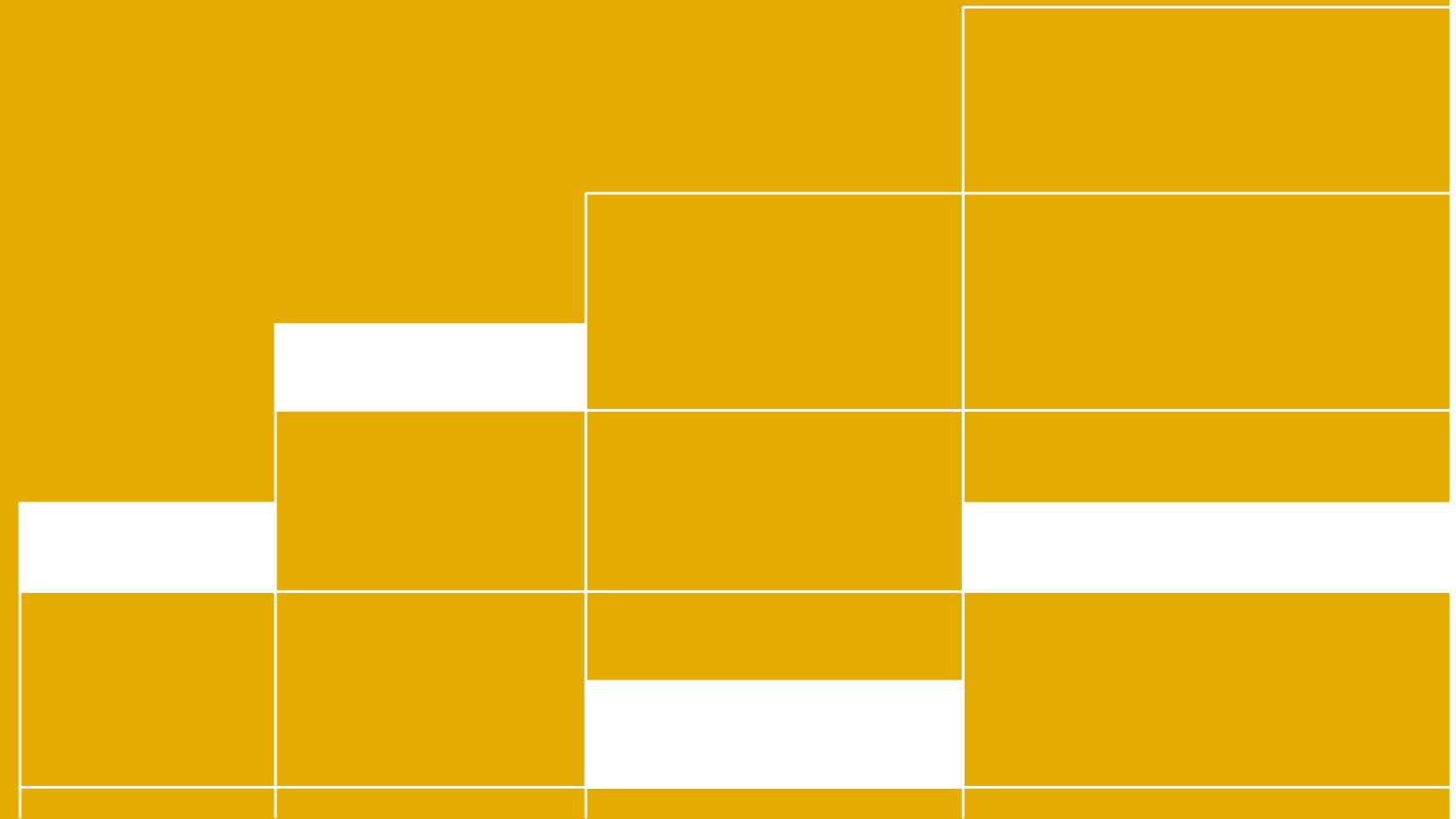

# TETRIS



Wall display unit  
W 600 x D 300 x H 300 mm



Wall display unit  
W 900 x D 300 x H 300 mm



Wall display unit  
W 1200 x D 300 x H 300 mm



Wall display unit  
W 1500 x D 300 x H 300 mm



Wall display unit  
W 900 x D 300 x H 140 mm



Display Planter unit  
W 2500 x D 400 x H 1975 mm



Display Planter unit  
W 2820 x D 400 x H 1805 mm



Display Planter unit  
W 1430 x D 300 x H 1155 mm



Storage unit  
W 900 x D 400 x H 1775 mm



Storage unit  
W 900 x D 400 x H 1775 mm



Storage unit  
W 900 x D 400 x H 1775 mm



Storage unit  
W 1200 x D 400 x H 1775 mm

# TETRIS



Table with storage unit  
W 1500 x D 900 x H 750 mm



Table with storage unit  
W 1500 x D 1500 x H 750 mm



High Table with storage unit  
W 1500 x D 600 x H 1000 mm



Storage & shoe rack unit  
W 1800 x D 450 x H 750 mm



Library cum display unit  
W 1200 x D 450 x H 1200 mm



Display, Planter with TV unit  
W 2120 x D 400 x H 1755 mm



Library cum display unit  
W 3780 x D 450 x H 1035 mm









Display & Storage unit with Table  
W 2160 x D 400 x H 1615 mm



Storage with planter unit  
W 2120 x D 1700 x H 1755 mm



Display & library unit with reading space  
W 2100 x D 450 x H 1815 mm

- | PLB           |   | Metal Powder Coating |   |
|---------------|---|----------------------|---|
| Thansau Maple |  | Black                |  |
| Everest White |  | White                |  |
| Gothic Grey   |  | Silver Grey          |  |

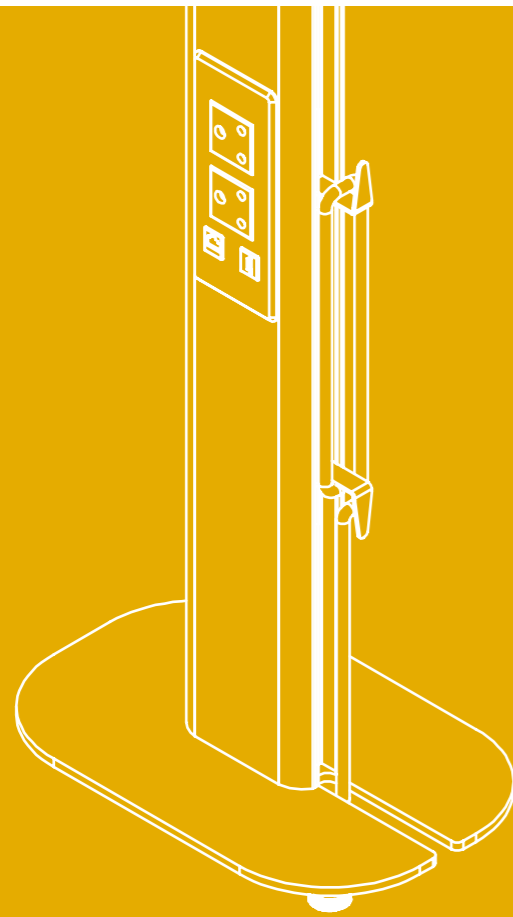

# Power Tower

A movable power tower for an office is a compact and convenient solution for powering and charging devices. It features multiple outlets. The tower is designed to be easily moved around the office, making it a versatile addition to any workspace. With its sleek and modern design, it can blend in seamlessly with any office decor. It also ensures safety and security of power supply for all devices in the office, it can also help in reducing the use of multiple power strips, thus reducing the risk of overloading and fire hazards.

# 12



Without Castors



With Castors

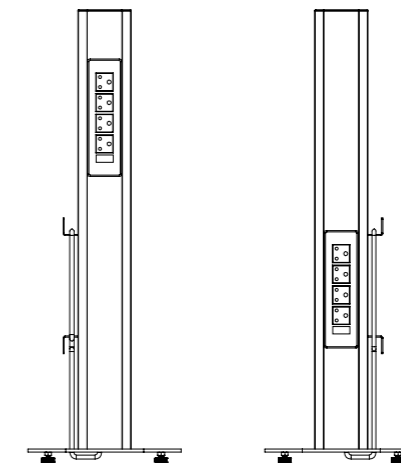
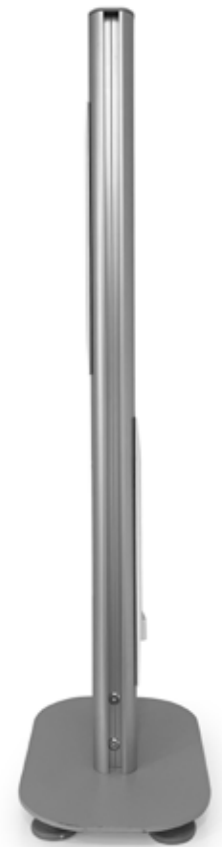

FRONT

BACK

1 + 1 Switch Plate, 4 Power Sockets in each Plate  
L 305 x D 197 x H 900 mm

# Acoustic Screens

Rather than create permanent and immovable divisions in your office space, we have created a range of screens to bifurcate the various areas in your office. Our acoustic office dividers, suspended baffles & wall panels are designed to reduce travelling sounds with high-quality acoustic properties & create softer soundscapes. These Screens can be reconfigured at anytime to create either a large open office space which encourages interaction, or siloed departments which encourages focus and growth.

# 13

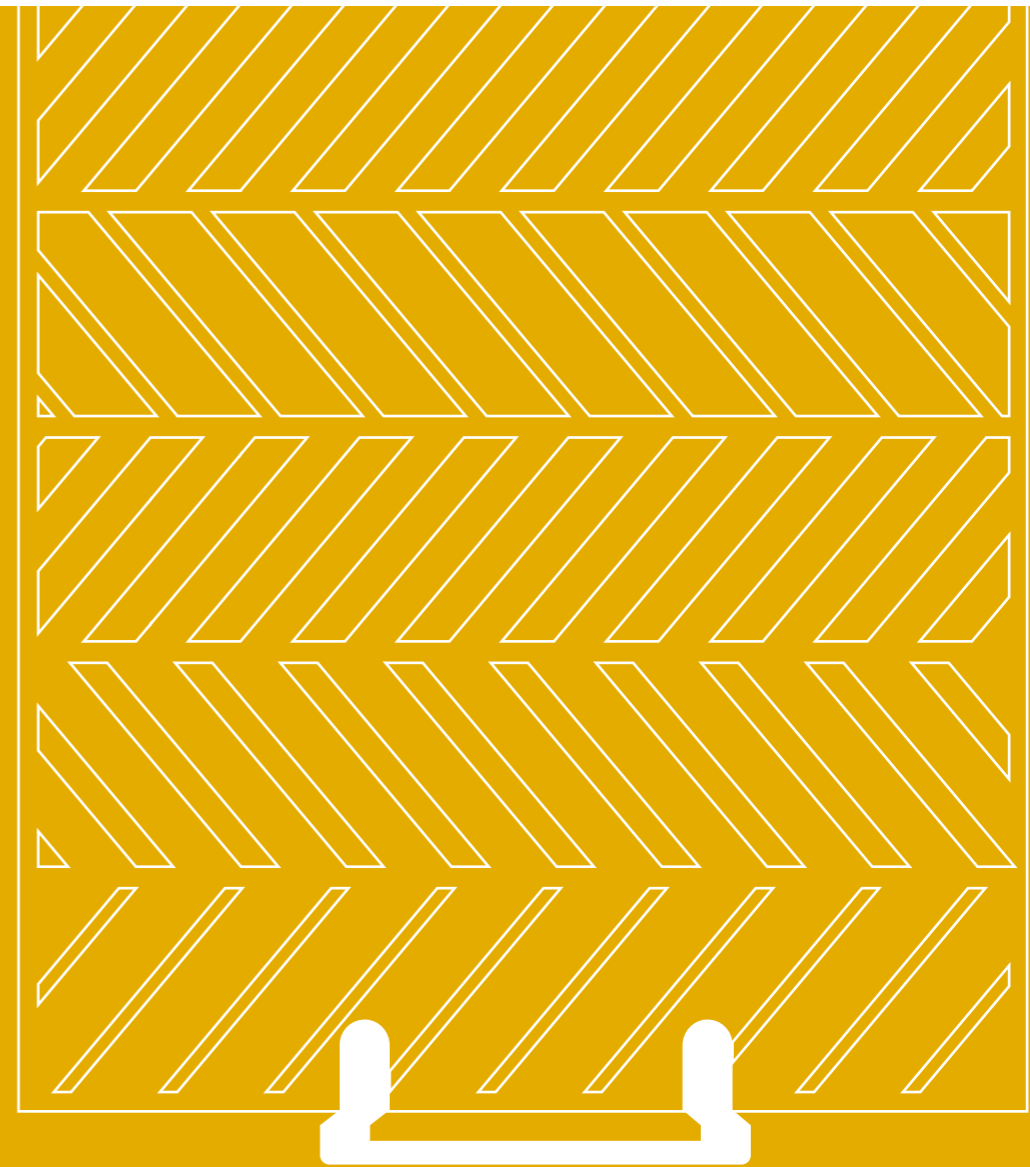

# GENESIS FREE STANDING PANELS



Available with and without Castors

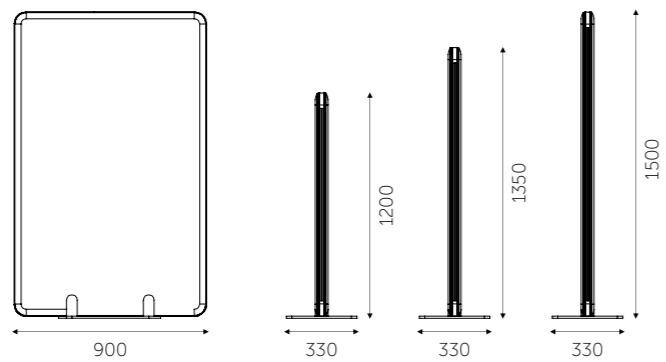

# PET PANELS

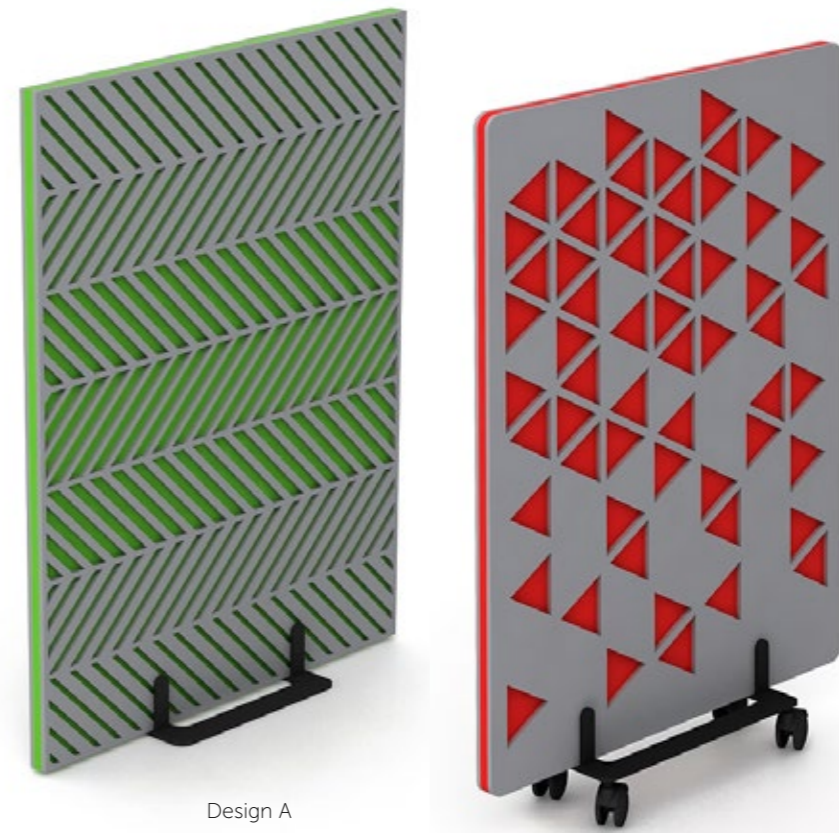

Design A

Design B

Available with and without Castors

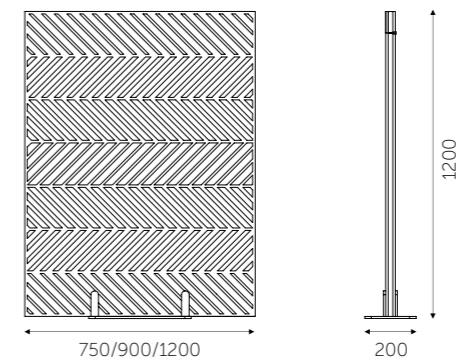

Thales



# Fabrics & Finishes

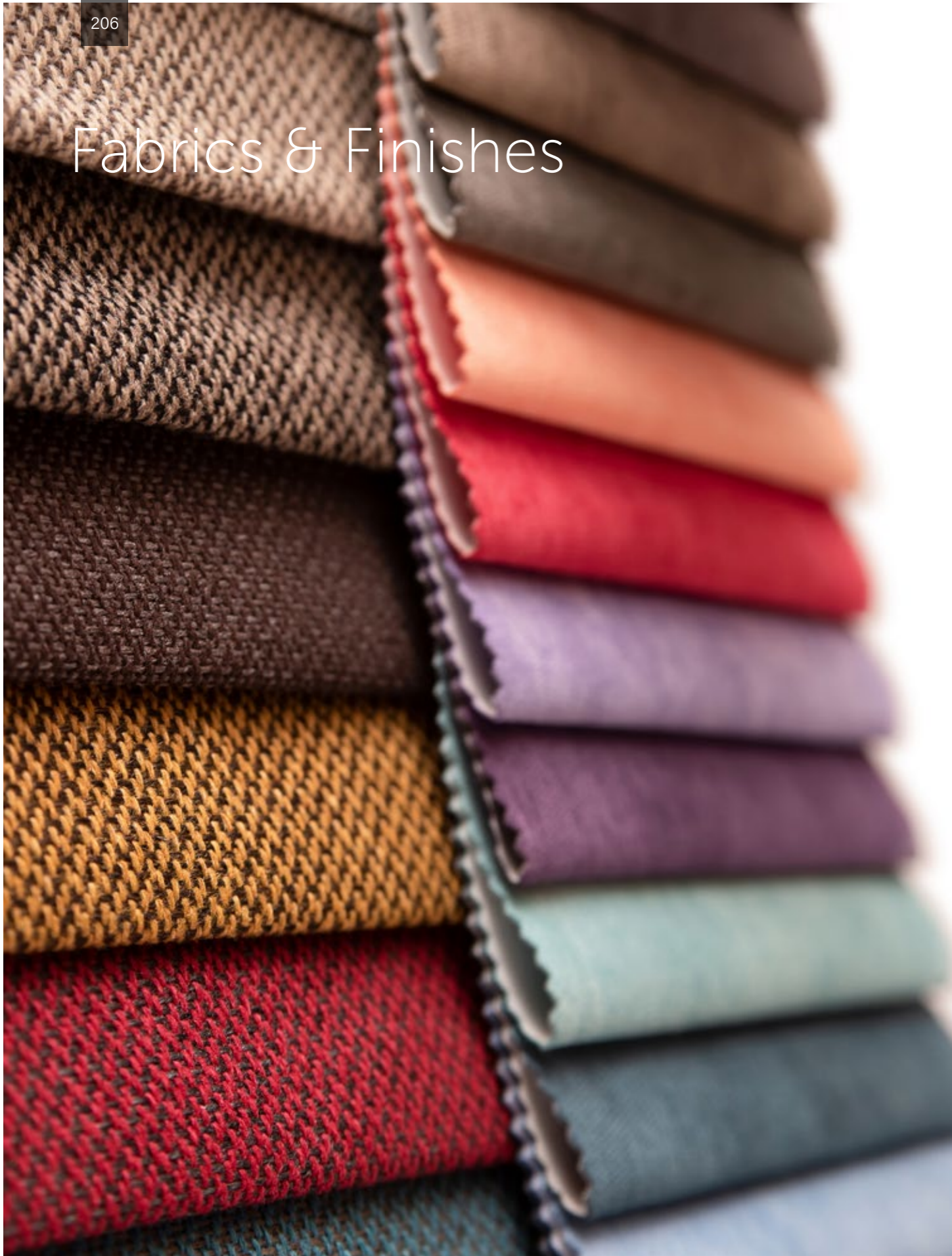

# Fabric Shades

## SF SERIES

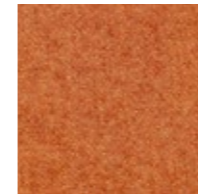

SF-04  
Trangerine Orange

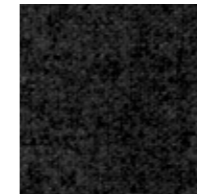

SF-05  
Raven Black

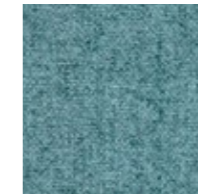

SF-07  
Aqua Blue



SF-08  
Lavender Purple

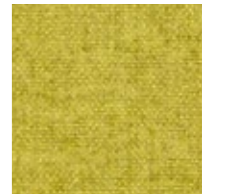

SF-11  
Kiwi Green

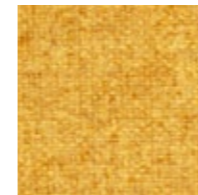

SF-19  
Canary Yellow

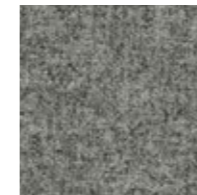

SF-21  
Ash Grey

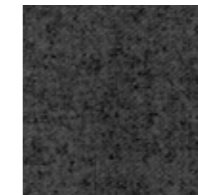

SF-25  
Stone Grey

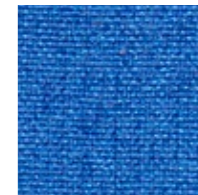

SF-30  
Ice Blue

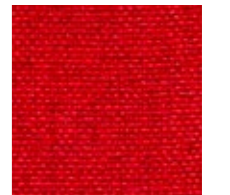

SF-31  
Tulip Red

## PUNCH SERIES



Punch 53347

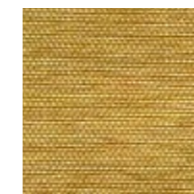

Punch 54012



Punch 58736



Punch 55216



Punch 58705



Punch 54015



Punch 58633



Punch 52208



Punch 59138



Punch 54011

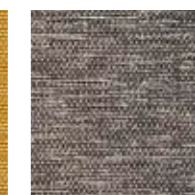

Punch 58735

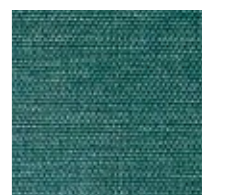

Punch 56133



# Leatherette

## GRANA VO SERIES

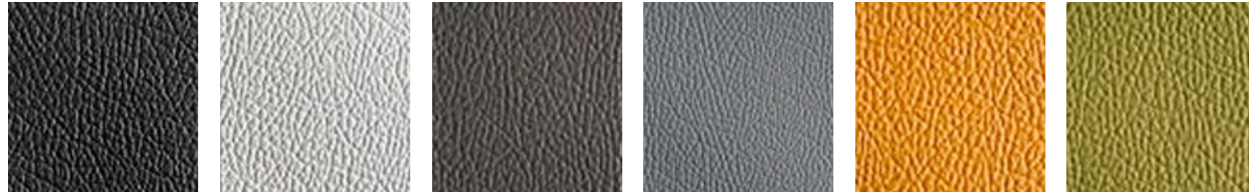

FP-01 Black    FP-02 White    FP-03 Dark Grey    FP-04 Light Grey    FP-05 Yellow    FP-06 Light Green



FP-07 Dark Green    FP-08 Light Tan    FP-09 Dark Tan    FP-10 Mushroom    FP-11 Sea Blue    FP-12 Dark Blue

# Powder Coating



Black    Dark Grey    Silver Grey



Moon Light Grey    Ivory    Feather White

# Laminate



Classic Planked Walnut    Mangfall Beech    Choco Saw Line    Sandy Saw Line    Napa Oak    Sunoma Oak

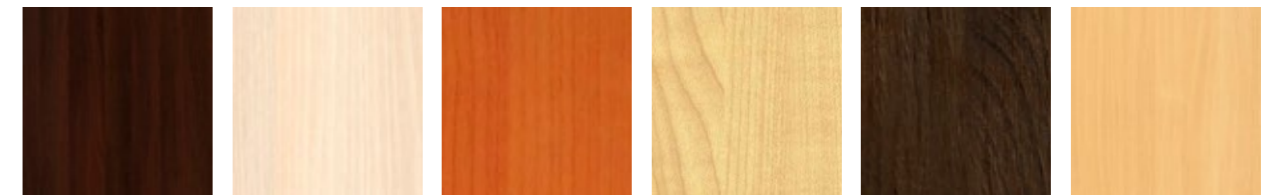

Moldau Acacia D    Moldau Acacia L    Oxford Cherry    Thansau Maple    Chestnut Dark    Bavarian Beech

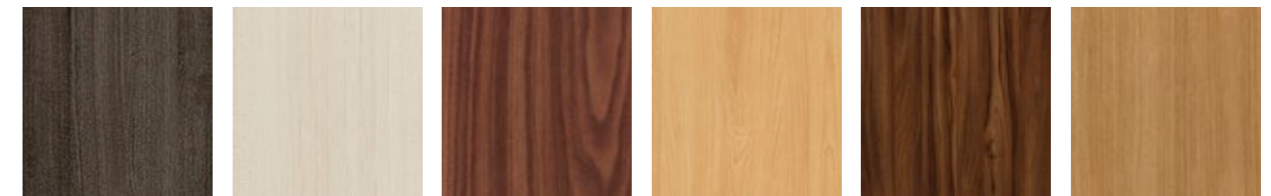

Thai Teak    White Teak    American Walnut    Intal Beach    Classic Walnut    Urban Teak



Gothic Grey    Slate Grey    Charcoal    Black    Lyons Walnut    Highland Pine

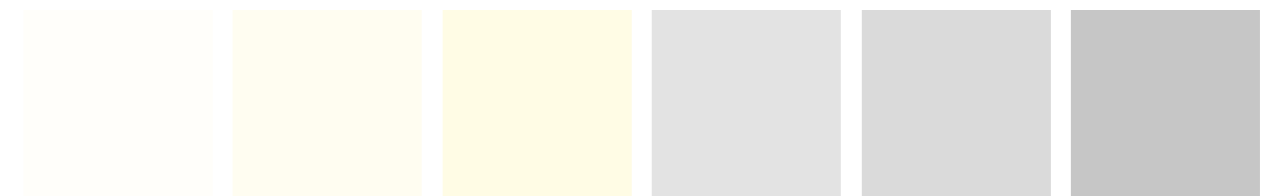

Everest White    Frosty White    Ivory    Silver Grey    Warm Grey    Metal Grey



Yellow    Electric Blue    Blood Red    Super White

# PAN India & International Network



**FEATHERLITE PRODUCTS (P) LTD.**

16/A, Millers Road, Vasanthnagar, Bangalore - 560 052.

**CUSTOMER CARE**

080 4719 1010

[sales@featherlitefurniture.com](mailto:sales@featherlitefurniture.com)

[www.featherlitefurniture.com](http://www.featherlitefurniture.com)

**Present in 66 locations**

across India, also in Nepal, Sri Lanka, and U.A.E.



ONLINE STORE



STORE LOCATOR